

***TOWNSHIP OF BLANDFORD-BLENHEIM***

***MUNICIPAL SERVICING STANDARDS***

***URBAN AND RURAL DEVELOPMENTS***



**K. SMART ASSOCIATES LIMITED**  
85 McIntyre Drive  
Kitchener ON N2R 1H6

## ***CONTENTS***

Chapter 1	Development Procedures
Chapter 2	Development Standards
Chapter 3	Applicable Provincial Drawings and Specifications
Chapter 4	Sanitary and Water Distribution Systems
Chapter 5	Subdivision Specifications for Electrical Distribution Systems
Chapter 6	Blandford-Blenheim Specifications for Street Lighting
Chapter 7	Preparation of Plans and Specifications
Chapter 8	Township Standard Drawings
Appendix A	Recommended Street Lighting

**THE CORPORATION OF THE  
TOWNSHIP OF BLANDFORD-BLENHEIM**

\_\_\_\_\_, 20\_\_

Moved By: \_\_\_\_\_

Seconded By: \_\_\_\_\_

THAT the Council of the Township of Blandford-Blenheim hereby adopts the  
Municipal Servicing Standards, for the Township of Blandford-Blenheim , as prepared by  
K. Smart Associates Limited, Kitchener, Ontario.

Mayor \_\_\_\_\_

# **TOWNSHIP OF BLANDFORD-BLENHEIM**

## **MUNICIPAL SERVICING STANDARDS**

### **CHAPTER 1**

#### **DEVELOPMENT PROCEDURES**

The following development procedures shall apply to but not limited to the following;

- Plan of Subdivision
- Site Plan agreement
- Severance agreements
- Fill by-law

#### DEVELOPMENT PROCEDURES

1. The developer and/or the developer's consultant shall arrange for a pre consultation meeting with the Township
2. Submit preliminary Draft Plan of Subdivision to Township for consideration, discussion and comment.
3. Upon Township review, Draft Plan is submitted to County for approval along with application fees for County and Township services.
4. Submit Draft Plan plus all required reports to outline methods of storm drainage, stormwater management, sanitary waste disposal, water supply and other applicable services. Where private water supply and/or sewage disposal is provided the reports shall outline the lot's suitability to provide for individual wells and to accept septic tank tile bed installations.
5. Upon Draft Plan approval, the Developer may request in writing that the Township prepare a Subdivision Agreement. Subdivider provides cash deposit for Township costs of preparing Subdivision Agreement.
6. Township provides Developer with copy of Municipal Engineering Standards and policies re imposed levies, park land fees, and other policies applicable to project. Preparation of design commences.
7. Developer prepares and submits two copies of plans, design calculations and indicates any phases, special provisions or specifications of the municipal services to be provided. Applicable OPSS and OPSD to be listed but not to be submitted. Generally a maximum of 25 lots will be authorized by the County of Oxford.
8. Township returns one set of plans, specifications and design calculations to the Developer with any required revisions.

9. Developer resubmits plans, specifications and design calculations to the Township for final approval, together with applications for submission to all agencies and authorities.
10. Provided that the final submission is satisfactory, Township initials plans and specifications approved for construction and signs approval application forms.
11. After receiving all agencies and authorities approval, the Developer shall satisfy the financial and other requirements of the Township as set out in the Subdivision Agreement after which the Township shall execute the Subdivision Agreement and authorize registration of the plan of subdivision. Construction of pre-servicing can then begin.
12. If not pre-servicing the developer shall provide evidence of registration of plan and Township authorizes construction to start.
13. Construction by the Developer or a Contractor on his behalf of all municipal services in accordance with the approved Subdivision Agreement, plans and specifications, and supervised by the Developer's Engineer with periodic inspection by the Township and its Engineer.
14. Developer submits to the Township service testing reports and construction reports together with a request for preliminary approval of the services.
15. Township grants preliminary approval subject to any deficiencies being corrected by the Developer.
16. Upon completion of deficiencies and all other requirements of the Subdivision Agreement, the Township issues performance acceptance certificate and maintenance period commences.
17. During maintenance period Developer maintains all of the municipal services.
18. Developer corrects any final deficiencies in the services at the end of the maintenance period, and then applies for final acceptance and assumption of the road.
19. A digital copy of the As-Constructed drawings shall be provided in PDF and AutoCAD format to the Township.
20. Township discharges the Developer's responsibilities as set out in the Subdivision Agreement.

**TOWNSHIP OF BLANDFORD-BLENHEIM**  
**MINIMUM MUNICIPAL SERVICING STANDARDS**

**CHAPTER 2**

**DEVELOPMENT STANDARDS**

A. Stormwater Management

General: The rational method can be used for minor storm systems with catchbasins for street and rear lot drainage.

Computer modeling such as MIDUSS, SWMM or HEC RAS shall be used for major systems using open channels, creeks, roadways, swales and/or boulevard capabilities.

The design modeling shall be based on the criteria included below. Unit Hydrograph methods may be used with prior approval of Township Engineer.

Intensity: - Intensity/Duration Curves as per Standard STD-1 attached.  
 - 5 year return period (minor system)  
 - 100 year return period (major system)  
 - 10 year return period (trunk sewers - determined by Township)

Inlet Time: As calculated; 10 minutes minimum

Storm Duration: 3hr Chicago Storm

Runoff	Asphalt concrete, roof areas	0.90 - 1.00
Coefficients:	Gravel	0.80 - 0.85
	Grassed areas, parkland	0.15 - 0.35
	Commercial	0.75 - 0.85
	Industrial	0.65 - 0.75
	Single family dwelling	0.40 - 0.45
	Semidetached	0.45 - 0.60
	Row housing, townhousing	0.50 - 0.70
	Apartments	0.60 - 0.75
	Institutional	0.40 - 0.75

Pipe Material and n Value:	Concrete	n = 0.013
	Polyvinylchloride	n = 0.013
	Polyethylene	n = 0.013
	Concrete or plastic drain tile for special uses.	

Parking Lot Storage: Orifice control on outlet pipe

- Orifice size: Minimum orifice size shall be 75mm.
- Quality Control: 80% suspended solid removal
- Infiltration: Infiltration of roof water shall be considered in all areas where soils permit. A geotechnical review will be required.
- LID Techniques: Consideration shall be given to LID techniques such as;
- bioretention
  - bioswales
  - infiltration
  - permeable pavement
  - etc.

Storm water management techniques shall follow MOE design guidelines and shall be necessary where outlet flows exceed outlet capacities and/or where required as a condition of Draft Plan approval.

Post development storm water flows leaving the lands to be developed shall not exceed pre-development storm water flows for rainfall events with return periods of two (2) years to hundred (100) years inclusive. In addition consideration shall be given to the Regional storm water flows.

If a proposed development intends to utilize an existing storm sewer as an outlet, proof that additional capacity exists within the storm sewer to accommodate flows from the proposed development must be provided.

MIDUSS model output files or other computer model files (if approved by the Township Engineer), plus plans of drainage areas shall be submitted for review and approval.

Depressing catchbasins below the normal gutter grade, or constructing asphalt basins around catchbasins will not normally be permitted by the Township.

Where rear lot or side yard swales are used, a minimum grade of 2.0% with catchbasins at 90m (300') intervals is required. In no case will an overland run exceeding the above limits be allowed unless it is an open channel. Easements of a sufficient width to provide access for maintenance by the Township are required for all back lot storm pipe drains or open channels.

## B. STORM SEWERS

Capacity: Manning's Formula, flowing full at peak discharge.

Private Drain Connections:	- Special sizing considerations required where house connections are provided as outlined herein. - Minimum diameter - 100mm (4") White - Minimum grade 2%
Minimum Size:	250mm (10 inch diameter) catchbasin leads 300mm (10 inch diameter) mains 675mm (27 inch diameter) radius pipe
Minimum Cover:	1.5m (4.9 feet)
Minimum Velocity:	0.75m (2.5 feet) per second
Maximum Velocity:	4.5m (15 feet) per second
Manhole Diameter:	Minimum of 1200mm (48")
Manhole Spacing:	90m (300 feet) or less desirable 120m (400 feet) maximum
Minimum Slope for Catchbasin Leads:	2%
Drop Manhole:	Required where inlet and outlet differ by more than 0.9m (3 feet)
Catchbasin Spacing:	- 90m (300 feet) - The highest catchbasin shall be located a maximum of 90m (300 feet) from the high point on the road. - Double catchbasins required at low points in roads.
Catchbasin Sump:	0.60m (2 feet) deep in 0.60 x 0.60m (2 foot x 2 foot) catchbasins 0.30m (1 foot) deep in 1.20m x 1.20m (4 foot x 4 foot) catchbasins, or 16 cubic feet of storage.
Invert Drops:	Where pipes enter and leave at the following angles: 90 Deg. = 60mm (0.2 feet) 45 Deg. = 30mm (0.1 feet) 0 Deg. = --mm (-- feet)
Gaskets:	All storm sewer shall be bell and spigot with gasket. Where open joints are allowed or requested, filter fabric joint wrapping is required.
Infiltration:	0.05 litres per millimetre diameter per 30 metres (0.25 gallons per inch diameter per 100 feet) of sewer per hour where gasketed joints are required.



Videotaping: Prior to start of maintenance and prior to acceptance of any new storm lines, a videotape plus report must be provided to the Township. Catchbasin leads and private connections do not require videotaping.

All storm drain materials, components, methods to be in accordance with applicable OPSD and OPSS.

All storm catchbasins, catchbasin manholes and manholes shall be:

1. Constructed with grade adjustment rings for final grade. A maximum of 150mm (6") grade adjustment rings shall be used. If more grade adjustment is required, additional manhole or catchbasin sections shall be used. Bricks will not be accepted.
2. Where multiple rings are used, the upper grade ring is to be constructed of an approved rubber product.
3. Catchbasins and Catchbasin Manholes shall NOT be benched
4. Manholes shall be benched. Channels are to be smooth and true to line and grade. Channels may be formed of concrete or sewer pipe neatly cut off.

Safety grading (landings) are to be provided in deep manholes. Manholes deeper than five (5) metres (sixteen (16) feet) measured from the top of frame to the lowest invert are to be installed with a safety grating. Details of the safety grating are to be submitted to the Township Engineer.

Energy dissipating structures will be required wherever the velocity of flow at a storm sewer or drain outlet exceeds 2.4 metres per second (8 f.p.s.). For low volumes and velocities riprap on filter fabric protection may be sufficient. For greater volumes and velocities more formal concrete structures will be required.

Corrugated metal pipe shall be used to protect any drain outlet into an open channel. Angular and graded stone riprap protection, unless otherwise specified, shall be built around the corrugated pipe and shall be extended downstream a minimum distance of 1 metre (3 feet). The protection shall extend to the top of the backfilled trench and below the pipe to 300mm (12") along the streambed. The protection shall also extend 600mm (2') into undisturbed soils on either side of the backfilled trench. Where the outlet occurs at the end of an open ditch the stone riprap protection will extend all around the end of the ditch and to a point 1 metre (3') downstream on either side. Where heavy overflow is likely to occur, sufficient additional riprap shall be placed as directed by the Engineer to prevent the water cutting around the protection. A geotextile filter underlay shall be placed under all outlet protection. A concrete structure may be required to protect against heavy overflow if so indicated by the Township Engineer. The corrugated metal pipe up to 450mm diameter shall have a hinged metal gate on the outlet end to prevent the entry of small animals. Maximum spacing between bars shall be two inches. Larger diameter pipe protection to be reviewed at the time by the Township.

All design submissions shall include pipe strength and bedding calculations. In general, Granular "A" or 20mm (3/4") crushed stone shall be used for bedding with

sand cover for a minimum of 300mm (1 foot) above the pipe ("Class B"). Depending on the soils and pipe strength calculations, bedding types that differ from the above may be approved.

Marston formulae  $W_t = 1.0 \times I_c \times C_t \times T/A$  for concentrated loading or  $W_d = C_d \times W \times B_d$  for gravity earth loading shall be used. References to published tables or graphs may be used. OSPD tables may also be used. The Concrete Pipe Design Manual by ACPA may be used.

All open channels to have minimum side slopes of 3:1 and to be in accordance with STD-3. Outlets of pipes into ditches to have outlet headwall in accordance with OSPD.

Where concrete drain tile or corrugated plastic tubing are permitted for any part of the drainage works (on open farmlands only) the most recent OMAF edition of "Recommended Practice for Construction of Subsurface Drainage Systems" shall govern the work.

Where non gasketed joints are permitted, the joints shall be fully wrapped with filter fabric to MTO standards.

All trench backfill to be approved by geotechnical engineer. Granular trench backfill may be waived if a minimum depth of 900mm (36") of Granular B base course is provided.

Township policy on storm service (private drains) connection is as follows:

**If private drain connections (PDC's) are provided, a condition shall be included in the subdivision agreement that each lot shall install a sump pump and the Township recommends a backup sump pump as part of the hook-up and as per STD-8. No direct gravity connection will be permitted.**

**Where PDC's exist in the Township:**

1. (a) **During reconstruction - each owner should be contacted to determine if they have an existing connection when reconstruction of a road is started.**
- (b) **The owner shall use a sump pump as per STD-8.**
- (c) **Any replacement drains installed by Township forces shall be kept at existing depth so as to pick up any other existing drains.**
- (d) **Township will install PDC's at existing depth at time of construction if owner is planning to make hook-up immediately. The Owner shall use a sump pump as per STD-8.**

- (e) **Existing tile found to be blocked or substandard will not be connected to new system unless total replacement of private drain is made by homeowner at his expense in accordance with STD-8.**

Where private drain connections are required, a 100mm (4") diameter white PVC SDR28 drain will be provided. In general the said private drain connections are to be located three (3) metres left of the centerline of the lot.

Private drain connections are to be installed at a minimum grade of 2%. Minimum cover at the street line is to be 1.5 metres. In general, Class "B" bedding as for the main storm line shall be used. Backfill requirements are to be the same as for main sewers.

Connections to the main drain shall be by means of approved tees or saddle connections. Ends of private drain connections shall be plugged with approved caps and shall be marked by stakes with tie wires. Where private drain connections are connected to catchbasins or manholes, they shall be at elevation equal to the spring line of the main drain.

Where private drain connections are provided the connection shall be in accordance with Detail Drawing STD-8.

The preferred method for flow control is to use plugs that fit inside the pipes at the catchbasin walls. Opening sizes to be cut into the plugs are to be in accordance with design calculations (minimum size 75mm).

The Township may waive the requirement that connections be made to the private drain connection provided at the street for sump pump drains if the existing property is served by an alternative gravity outlet that is acceptable to the Township.

Where a private drain outlet is required for a storm drainage system the following shall apply:

- a) provide the necessary calculations and/or design notes in the Drainage Plan to satisfy the Township that a sufficient outlet is available.
- b) install any storm drainage works within the necessary trench such that a minimum of settlement results.
- c) topsoil and seed or gravel or hard surface the backfilled trench to give restoration equal to or better than the existing condition
- d) grout the pipe to any catchbasin or manhole if such constitutes the outlet
- e) backfill any laneway or roadway crossings in accordance with approved standards
- f) save and replace separately topsoils from all working areas
- g) compact all backfills
- h) provide manholes for inspection and maintenance at 400 foot maximum spacing

- i) where a new storm pipe is to join to an existing pipe that constitutes the outlet a manhole shall be used at the junction

To minimize the effects of siltation and sedimentation and erosion, the owner agrees to:

- a) have all aspects of any storm drainage outlet works backfilled and restored as soon as pipe installation is completed and inspected. All boulevards that are graveled, paved or seeded must be maintained until the expiration of all other maintenance periods for all other aspects of the public services.
- b) ensure that each catchbasin has a sump of minimum depth of 0.3m (1') below the invert of the lowest pipe connected thereto and to further ensure that each catchbasin is maintained and kept free of sediment and debris during construction and until such time as the public services are assumed by the Township and as directed by the Township Engineer.
- c) construct straw bale dykes and berms in accordance with an erosion & sediment control plan to be submitted to and approved by the Township Engineer.

C. ROADS (Applicable Cross Section is STD-2)

Minimum 20m (66') road allowance

Minimum 50 Km/H (30 M.P.H.) design

Minimum 8.5m (28') travelled surface (gutter line to gutter line)

Minimum 90mm (3") Asphalt Thickness in 2 lifts 40mm HL3 Surface, 50mm HL8 Binder (Surface coat not to be applied before 1 winter of consolidation).

Minimum 150mm (6") Granular "A" (Increased Thickness Per Soils Report).

Minimum 450mm (18") Granular "B" (Increased Thickness Per Soils Report), subject to the requirement of 900mm (36") if full granular backfill to sewer line is not used.

Minimum 10 mK (350') Vertical Curve (required if Algebraic grade difference is greater than 0.5%).

Minimum Intersection Radius 9m (30').

Maximum Road Grade (5%).

Minimum Road Grade (0.5%).

Minimum Crown (2%)

Street name and traffic control signs in accordance with Ontario Traffic Control Manual Recommended Standards.

Minimum Cul-de-sac Property Radius 21m (69'). No centre islands will be allowed. Full cul-de-sac paving is required.

Minimum Pavement Radius

- i) Intersections 9m (30')
- ii) Cul-de-sac 17m (55')
- iii) Temporary cul-de-sac 15.5m (51')

Concrete curbs, gutter on both sides of roadway as per drawing STD-2.

1.5m (5') sidewalk on one side of all streets, which are not cul-de-sacs except where noted differently by Township. Sidewalks shall not be constructed in front of a property until house construction is complete except where otherwise provided by the subdivision agreement. Sidewalks shall be constructed prior to the hard surfacing of the driveway.

All areas to be excavated or filled shall be stripped of topsoil and the topsoil stockpiled on site for re-use during final grading and seeding operations.

Bulbed corners or corners with less than 90 degrees on the interior angle are to be discouraged.

Sub Drains - to be provided unless found unnecessary by soils report.

Curb and Gutter - to be OPSD 600.04 on radius plus min. 3m past radii.  
- to be OPSD 600.10 on other portions.

Driveways are to conform to Standard STD-4 to STD-6 and to be a minimum of 150 mm (6") Granular A and 6" Granular B or a total of 10" Granular A and are to have 50mm (2") HL3 surface or other approved hard surface. The profile shall match road cross section. Paving not to be done until house construction and landscaping is complete.

Soils Report - required.  
- shall address pavement structure and subdrains.

Trees – Required in boulevard as approved by Township.

The following is a list of approved tree species;

- Amur Maple
- Tatarian Maple
- Sugar Maple
- Serviceberry
- Ironwood

- Japanese Lilac
- Red or White Oak
- Bur Oak
- Little leaf Linden

Boulevards - to be topsoiled (150mm minimum) and sodded. Boulevard construction not to be done until house construction is complete.

All road work components, materials, methods to be in accordance with applicable OPSD and OPSS.

The specifications and drawings shall provide for the following:

- a) rough grade the full width of the new road allowance prior to the installation and construction of the storm drainage system and prior to construction of curbs.
- b) keep all boulevards clear and free of all materials and obstructions which might interfere with the installation of electric, telephone, gas or other utilities.
- c) maintain, restore and/or regrade the roadway, shoulders, ditches and boulevards of any existing adjacent roads abutting the plan of subdivision and repair any damages made to existing public services on these roads both during and at completion of construction of internal roadways and to the satisfaction of the Township Engineer.
- d) ensure that frost treatment is provided as required by the Township for all installations or plant below existing roads.
- e) remove any contamination from, regrade, compact, and/or otherwise repair and replace the base course as directed by the Township Engineer prior to the placement of the asphalt pavement in order that the construction of the roadway shall not have suffered due to the use of the base course as a temporary roadway.

D. LOT GRADING AND DRAINAGE

Lot grading to be in accordance with Standard STD-7 attached.

Lot Grading Drawings

1. Show title block, table of revisions and north arrow on plan.
2. Indicate pavement elevations obtained from approved road profile at 25m intervals or opposite all lot corners.

3. Existing and proposed elevations should be shown on every corner of each lot and block.
4. Show proposed ground elevations around buildings.
5. Show existing contours.
6. Proposed elevations should be shown where sudden change of grade occurs. In the case of terraces and retaining walls, elevations of the top and the bottom are required.
7. Swales at a minimum 2% are required along all side and rear lot lines.
8. Sodded swales and storm drains should be shown on the plan wherever they are needed.
9. Drainage pattern should be indicated on the plan by means of arrows. Double stem arrows to be used for swales.
10. Show detail of swale.
11. Show minimum basement floor elevations and underside of footing elevations.
12. State the elevation and location of the controlling bench mark which is used.
13. Maximum driveway grade is 8%

#### Lot Grading Requirements

The data and tables on STD-7 should be used as a guide in planning the various types of lot grading illustrated.

The lot grading plan shall provide for proper drainage of all adjacent lands which drain through the said lands.

Swales should not be over ninety (90) metres in length without catchbasin and storm drain.

#### General

Details of all terracing and slope treatment shall be submitted with lot grading plans and detailed cross-sections provided if required by the Township Engineer.

All regional flood and Conservation Authority regulation lines must be indicated on lot grading plans where developments are adjacent to existing water courses.

Topsoil shall be stripped in all cut and fill areas and stockpiled for reuse during final lot grading operations.

A Lot Grading Plan, prepared and submitted for the development, will include any recreational or park areas.

Drainage swales are to be in accordance with Standard STD-7.

Where the subdivision has lots or roads in a treed area, a tree saving plan shall be prepared.

E. EROSION CONTROL

The Township will require the Owner to provide an erosion control plan to be approved by the Township Engineer for all developments and subdivisions. Individual lot grading plans may be requested by the Township to provide an erosion control plan.

F. UTILITIES AND STREET LIGHTING

All primary Hydro shall be underground and placed in accordance with current Hydro One standards. Secondary leads for lighting and services, Telephone and other utilities shall also be underground and shall be placed in accordance with the current utilities regulations and standards and in accordance with Road Cross-Section Drawings STD-2.

All developments shall be provided with adequate street lighting in accordance with the Township's specifications for street lighting which are attached as Chapter 6.

Satisfactory evidence that the Developer has made arrangements with ETP, Hydro One and the Township to provide for the installation of hydro and street lighting must be submitted to the Township prior to the execution of a Subdivision Agreement. Where such arrangements have not been made, the Developer shall provide separate drawings stamped by a Professional Engineer (Electrical), showing the details of the hydro and street lighting.

G. LANDSCAPING OF PARK AND RECREATIONAL AREAS

The Township shall request that the Park or Recreational Areas dedicated for the development be graded and seeded so that they are suitable for recreational use.

The area to be dedicated for park use shall be reviewed with the Township on submission of the Preliminary Draft Plan and any special requirements for grading and landscaping finalized at this time. The Township may also request that a different area than that proposed by the Developer be set aside for a park due to the physical features on site.



The subdivision agreement may require separate funds to be provided for park equipment and for tree planting in the park.

H. STREET NAME SIGNS

The Township will supply and erect all street name and traffic control signs. An invoice will be submitted to the developer (subdivider) for the costs of such.

I. FENCES

Highway fences shall be in accordance with OPSS 540 and OPSD 971.1010. Chain link fences shall be galvanized and have both top and bottom bars and shall be in accordance with OPSS 541 and OPSD 972.130.

During the site plan review the details and ownership of the proposed fence shall be reviewed by the Township. In general if the fence is abutting the Township owned lands then the Township will maintain ownership of the fence and the fence shall be chain link. If a fence is required alongside an existing residential area then the fence will be board on board and the ownership will be designated to the new development. If a fence is required alongside an existing farm land then the fence shall be page wire fence and the ownership will be designated to the owner of the farm land.

**CHAPTER 3**

**ONTARIO PROVINCIAL STANDARD SPECIFICATIONS AND DRAWINGS**

**(OPSS AND OPSD)**

**TO BE USED WHERE APPLICABLE IN**

**TOWNSHIP OF BLANDFORD-BLENHEIM**

**(NOT NECESSARILY COMPLETE LIST)**

A. STANDARD SPECIFICATIONS (OPSS)

<u>Number</u>	<u>Title</u>
201	Construction Specification for Clearing, Close Cut Clearing, Grubbing and Removal of Surface and Piled Boulders
206	Construction Specification for Grading
310	Construction Specifications for Hot Mix Asphalt
351	Construction Specifications for Concrete Sidewalk
353	Construction Specifications for Concrete Curb and Gutter Systems
401	Construction Specifications for Trenching, Backfilling and Compacting
402	Construction Specifications for Excavating, Backfilling and Compacting for Maintenance Holes, Catch Basins, Ditch Inlets and Valve Chambers
405	Construction Specifications for Pipe Subdrains
407	Construction Specifications for Maintenance Hole, Catch Basin, Ditch Inlet and Valve Chamber Installation
410	Construction Specifications for Pipe Sewer Installation in Open Cut
421	Construction Specifications for Culvert Installation in Open Cut
441	Construction Specifications for Watermain Installation in Open Cut
501	Construction Specifications for Compacting
511	Construction Specifications for Rip-Rap, Rock Protection and Granular Sheeting
517	Construction Specifications for Dewatering of Pipeline, Utility and Associated Structure Excavation
518	Construction Specifications for Control of Water from Dewatering Operations
615	Construction Specifications for Erection of Poles
617	Construction Specifications for Installation of Roadway Luminaries
771	Construction Specifications for Standard Highway Fence
772	Construction Specifications for Chain Link Fence
802	Construction Specifications for Topsoil
803	Construction Specifications for Sodding
804	Construction Specifications for Seed and Cover

B. STANDARD DRAWINGS (OPSD)

<u>Number</u>	<u>Title</u>
200.010	Earth/Shale Grading Undivided Rural
207.041	Subdrain Pipe, Open Graded Drainage Layer, Hot Mix Asphalt, Concrete, or Composite Pavement
208.010	Benching of Earth Slopes
209.010	Rural Pavement Widening
310.010	Concrete Sidewalk
310.030	Concrete Sidewalk Ramps at Signalized Intersections
400.020	Cast Iron, Square Frame with Square Flat Grate for Catch Basins, Herring Bone Openings
401.010	Cast Iron, Square Frame with Circular Closed or Open Cover for Maintenance Holes
401.020	Cast Iron, Circular Frame with Circular 745mm Cover for Maintenance Holes
403.010	Galvanized Steel, Honey Comb Grating for Ditch Inlet
405.010	Maintenance Hole Steps, Hollow
600.010	Concrete Barrier Curb with Wide Gutter
600.030	Concrete Mountable Curb with Wide Gutter
605.040	Asphalt Spillways
608.010	Method of Termination for Concrete Curb and Gutter
610.010	Catch Basin Frame with Grate Installation at Curb and Gutter
701.010	Precast Concrete Maintenance Hole, 1200mm diameter
701.011	Precast Concrete Maintenance Hole, 1500mm diameter
701.012	Precast Concrete Maintenance Hole, 1800mm diameter
701.021	Maintenance Hole Benching and Pipe Opening Alternatives
704.010	Precast Concrete Adjustment Units for Maintenance Holes, Catch Basins and Valve Chambers
705.010	Precast Concrete Catch Basin, 600 x 600mm Depth
705.030	Precast Concrete Ditch Inlet, 600 x 600mm Depth
708.010	Catch Basin Connection for Rigid Main Pipe Sewer
708.020	Support for Pipe at Catch Basin or Maintenance Hole
802.010	Flexible Pipe, Embedment and Backfill, Earth Excavation
802.013	Flexible Pipe, Embedment and Backfill, Rock Excavation
802.014	Flexible Pipe, Embedment in Embankment, Original Ground: Earth or Rock
802.030	Rigid Pipe Bedding, Cover, and Backfill, Type 1 or 2 Soil – Earth Excavation
802.031	Rigid Pipe Bedding, Cover, and Backfill, Type 3 Soil – Earth Excavation
802.032	Rigid Pipe Bedding, Cover, and Backfill, Type 4 Soil – Earth Excavation
802.033	Rigid Pipe Bedding, Cover, and Backfill, Rock Excavation
802.034	Rigid Pipe Bedding and Cover in Embankment, Original Ground: Earth or Rock

B. STANDARD DRAWINGS (OPSD) - Continued

<u>Number</u>	<u>Title</u>
803.030	Frost Treatment – Pipe Culverts, Frost Penetration Line Below Bedding Grade
804.040	Concrete Headwall for Sewer or Culvert Pipe Outlet
804.050	Grating for Concrete Endwall
805.010	Height of Fill Table, Round Corrugated Steel Pipe and Structural Plate Corrugated Steel Pipe
806.020	Height of Fill Table, Dual Wall Corrugated Polyethylene Gravity Sewer Pipe - 320 Kpa and Rsc 160
807.010	Height of Fill Table, Reinforced Concrete Pipe - Confined Trench Class 50-D, 65-D, 100-D, and 140-D
809.010	Perforated Pipe Subdrain in Granular Trench, Main Storm Sewer Connection to Drainage Structure
810.010	General Rip-Rap Layout for Sewer and Culverts Outlets
810.020	General Rip-Rap Layout for Ditch Inlets
912.532	Guide Rain System, Steel Beam, Barricade, installation
971.101	Fence, Highway, in Earth, Shale, Loose Rock, or Friable Rock, Installation
972.130	Fence, Chainlink Installation - Roadway
1003.010	Cast-in-Place Maintenance Hole Drop Structure Tee
1006.010	Sewer Service Connections - for Rigid Main Pipe Sewer
1103.010	Concrete Thrust Blocks for Tees, Plugs, and Horizontal Bends
1104.010	Water Service Connection 19 and 25mm Diameter Sizes
1104.030	Blow Off, Installation
1105.010	Hydrant Installation
2245.020	Minimum Vertical Clearances for Aerial Cable Systems

Note: Where any OPSD or OPSS is in conflict with other Standards, Drawings or Specifications enclosed herein, the latter shall apply.

**CHAPTER 4**

**Sanitary Sewer and Water Distribution Systems  
Oxford County Specifications**

Specifications are available on the Oxford County website,

[www.oxfordcounty.ca](http://www.oxfordcounty.ca)

or by contacting Oxford County Customer Service:

County of Oxford  
21 Reeve Street, P.O. Box 1614  
Woodstock, ON N4S 7Y3  
Phone: 519-539-9800  
1-866-537-7778

**CHAPTER 5**

**Subdivision Specifications  
for Electrical Distribution Systems**

Please Contact  
Hydro One

[www.hydroone.com](http://www.hydroone.com)

Hydro One Networks Inc.  
P.O. Box 5700  
Markham, ON L3R 1C8  
Billing and Service 1-888-664-9376  
Emergency 1-800-434-1235

## CHAPTER 6

### BLANDFORD-BLENHEIM

#### DESIGN CRITERIA – STREET LIGHTING

1. Source Type

All light sources shall be of the Light Emitting Diode Type or L.E.D. type.

2. Cobra Lamp Wattages

Composed of 32 to 92 High Performance L.E.D.'s. 42-92 Watt Lamp Wattage. Color Temperature 4000 Kelvin nominal, 70 CRI. Operating Lifespan 80,000 hours after which 50% still emits over 70% of its original lumen output. Optical system (LE3) I.E.S. type III.

Township of Blandford-Blenheim has chosen a fixture supplied by

Leotek – GC1-40E-MV-2-GY-700

Leotek – GC1-30E-MV-2-GY-530

Philips- RFS-72W32LED4K-T-R3M-UNIV-DMG-RCD-NP

Philips- RFS-54W16LED4K-T-R3M-UNIV-DMG-RCD-NP

Decorative Lamp Wattages

Composed of 48 High Performance L.E.D.'s. 55-90 Watt Lamp Wattage. Color Temperature 4000 Kelvin nominal, 70 CRI. Operating Lifespan 80,000 hours after which the system emits 70% of its original lumen output. Optical system (LE3) I.E.S. type III.

Township of Blandford-Blenheim has chosen a fixture supplied by Philips as Model MPTC-55(80)W48LED4K-ES-LES-120-API-RC-NP, Model # L40U-STM-80W48 LED4K-R-LE3-120-API-RC-BKTX or approved equivalent.

3. Illumination Design Levels

All design criteria shall be in accordance with, or exceed current I.E.S. standards.

Lighting levels are measured in two ways Average Maintained Footcandles.

The metric equivalent of (A.M.F.C.) is measured in Lux. The conversion from Footcandles to Lux is  $(FC \times 10.76) = Lux$ .

The A.M.F.C.(Average Maintained Footcandles) and uniformity ratios for Municipal roads shall be:

<u>Type of Road</u>	<u>A.M.F.C.</u>	<u>Average to Minimum Ratio</u>
Arterial	0.8	3:1
Collector	0.6	4:1
Local	0.4	4:1
Rural Local	0.2	8:1
Walkways	0.2	8:1

A.M.F.C. to be within 0.05 of requirements.

Intersections shall have an illumination equal to the sum of values of the intersecting roadways.

4. Pole Locations

Preferred installation of street light fixtures is to be on one side of street. Staggered orientations of street light fixture require Municipal approval.

Poles shall be installed as per the municipality’s roadway standards.

5. Wiring

All wiring in new subdivisions to be underground and the lighting completed prior to occupancy.

Typical street light conductor to be 6/2 AWG copper CSA Type NMWU. Conductor to be direct buried in the utility trench. In road crossings, the conductor is to be installed in minimum 50mm diameter DBII conduit.

Cable in street light pole from hand-hole to luminaires shall be: non-metallic sheath cable 2 conductor CSA type NMWU(12/2 AWG CSA type NMWU)

6. Inspection

Final installation shall be inspected by and subject to the Township of Blandford-Blenheim & or E.S.A. inspection/approval.

7. Standard Design (Cobra Head)

a) Roadway Lighting

**Luminaire:** Shall be of the “Cobra Head” type, distribution III medium cut off, composed of 32-62 high-performance white LEDs, individually photo controlled and internally ballasted.

**Photometrics:** Shall be of the type (LE3), IES type III (asymmetrical). System rated IP66. Photometric performance shall be tested per LM63,



LM79 and TM15 (IESNA) in order to certify the performance of the fixture.

**Mounting Height:** Luminaires shall be mounted at a twenty five (25) foot height (7.6m).

**Bracket/Davit:** Shall be tapered elliptical aluminum. Brackets shall be bolted directly to the pole (banding is prohibited). Bracket lengths shall be as required to position the luminaire with two (2) feet + over the near edge of the travelled portion of the road. In no case shall the bracket exceed ten (10) feet.

**Poles:**

Shall be either spun concrete tapered (direct buried), or Tapered Aluminum (direct buried) and of sufficient size and structural capability to support the type of fixture as required and at the heights to meet mounting height requirement or as specified.

**Concrete**

Cross Section: Tapered Round

Finish: Smooth concrete

Colour: Natural concrete grey

**Aluminum**

Cross Section: Tapered Round

Finish: Rotary Polished Aluminum

Colour: Natural Aluminum

All materials shall be of the best quality and shall be vandal resistant with poly carbonate or glass lens or equivalent approved by the Vice President/Roads Superintendant.

8. **Decorative Design(Subdivisions)**

a) **Roadway Lighting**

**Luminaire:** Shall be of the “Lantern” type, distribution type III medium cutoff, composed of 48 high-performance white LEDs, individually photo controlled and internally ballasted.

**Photometrics:** Shall be of the type (LE3), IES type III (asymmetrical). System rated IP66. Photometric performance shall be tested per LM63, LM79 and TM15 (IESNA) in order to certify the performance of the fixture.

**Poles:** Shall be Decorative concrete (**Utility Structures Inc. (USI)**) poles (MH Rosemount) and of sufficient size and structural capability to support

the type of fixture as required and at the heights required or as illustrated in spec.

**Spacing:** Shall be on one side of the road spaced at 40m to 45m for Cobra head style installations. Staggered installation accepted only upon approval. Decorative light fixture installations require 25m to 30m distance (+/- 2m max) between fixtures on one side of street.

All materials shall be of the best quality and shall be vandal resistant with polycarbonate lens or equivalent.

**Disconnects:** The street light disconnect will be either an SL or SLM series from Pedestal Solutions Inc., or approved equivalent.

9. For recommended street lighting standards see appendix A

Project: **TOWNSHIP OF BLANFORD-BLENHEIM**  
 Lumec fixture : L40U-STM-80W-48LED4KR-ACDR-C-LE3-VOLT-RC-BKTX  
 Aluminous arm: NSB-5  
 USI Concrete pole: CA320A3ML60F CAMBRIDGE

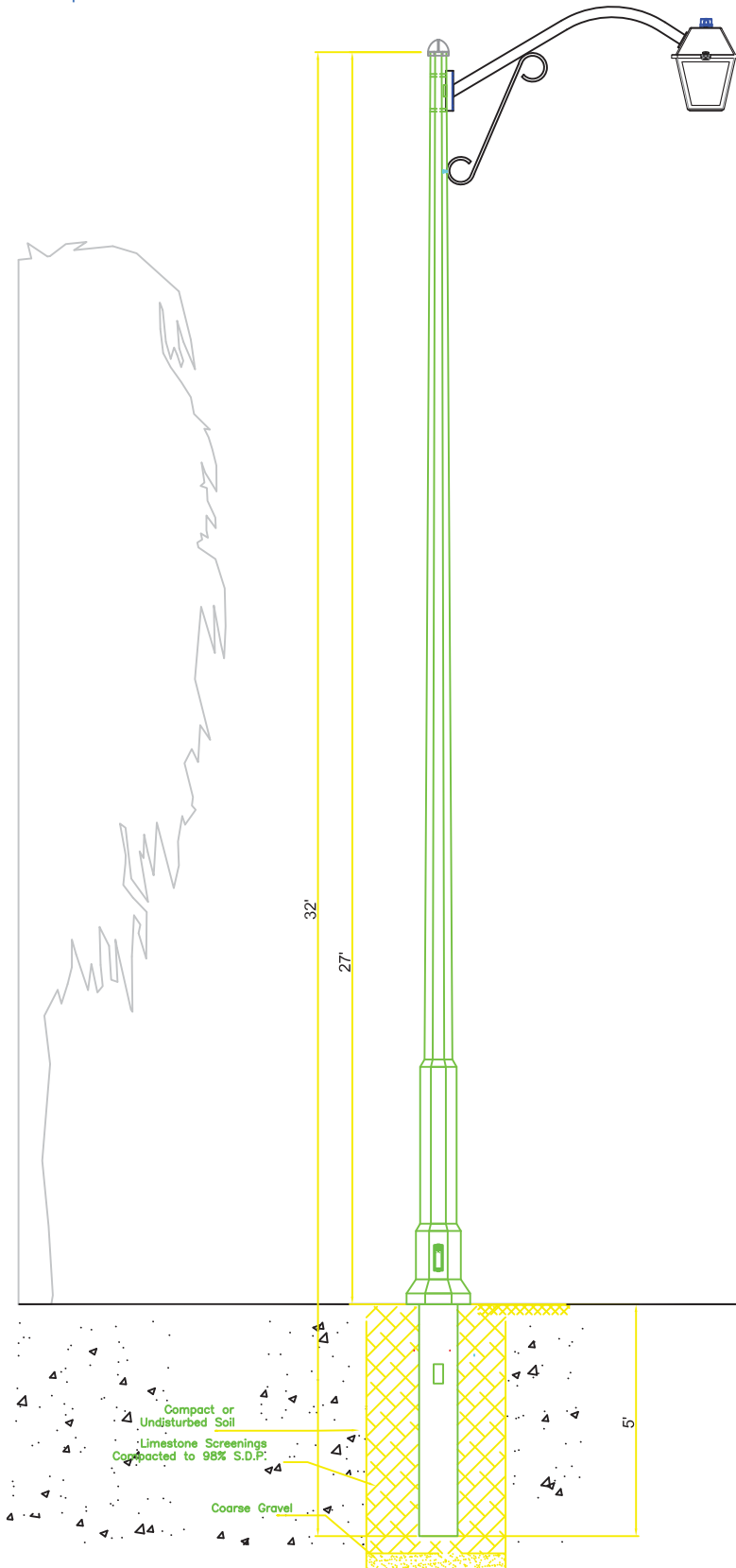

**LUMINAIRE:**

1. Head module: Mounting arm adaptor c/w cast aluminum hood (356 alloy). C/w integrated twist lock long life photocell c/w 20 Year warranty.
  2. Light engine : 80 W of power. TYPE 3, Cut-off. The light engine have 48 LED powered by an efficient LED driver which operates on 120 Volts. The light engine provides a (CRI) Color Rendering Index of 70 and 5480 lumens with 4000 K. All components are CSA/UL approved. Operating Lifespan 100,000 hours
  3. Opening System: provided by an hinged access door. The mechanism offers access to the lamp and ballast tray.
  4. Tool-free Driver module:  
LED Driver. Lamp starting capacity -30°C. Assembled on a removable stainless steel tray with quick disconnect Spun aluminum ballast cover. Quick disconnect connector. Single stainless steel retaining latch system. All components are UL approved.
  5. Surge Protector: 10KV surge protectors that protect Line-Ground, Line-Neutral and Neutral - Ground in accordance with IEEE/ANSI C62.41.2 guidelines.
  6. Base module: Four-sided cast aluminum body. Clear flat glass lens 1/8" thickness (#GGC) c/w gasketing.  
Wiring/hardware : Type TEW 14-7. 12" (30cm) minimum exceeding from luminaire. All electrical connections shall be made with quick-disconnect connectors. Neoprene and/or silicone gasketing is applied. All exposed hardware are stainless steel.
- ARM:**
1. Mounting plate mechanically secured by bolts. Pole diameter to be determined.
  2. Arm: 2-3/8"Ø bent aluminum tube.
  3. Decorative element, made of aluminum.
  4. Mounting plate to fix the luminaire.
- Wiring/hardware :All exposed hardware are stainless steel.  
 Finish : #BKTX (BLACK).  
 Textured finish. Electrostatically applied polyester powder coat paint (5 mils / 127 microns).

Dwg #: **B-BCoachRev1**  
 Scale/Ech:  
 Designer: **BH**  
 Date: **FEB 11, 2016**

Project: **TOWNSHIP OF BLANFORD-BLENHEIM SPEC**

Description: **27'-0" MH Pole 5' Arm Coach Head LED Fixture APPROVAL**

## CHAPTER 7

### PREPARATION OF PLANS AND SPECIFICATIONS

#### A. PLANS

##### A.1 General

All plans are to be on paper of metric size equivalent to 24-inches by 36-inches. A title block is to be used and placed in the lower right hand corner of the sheet. All drawings are to be in metric and are to be signed and sealed by the Engineer at a location provided in the title block.

Chainages are to be taken along the centreline of the road allowances. Station 000 is to be located at the intersection of centreline of road allowances and/or the intersection of the centreline of the road allowance and the centreline of an easement, right-of-way, etc. In general, chainages shall be the chainage of the centre of road allowance and/or easement.

The Plans shall include:

- a) Plan showing data to be on plan for Registration
- b) A Lot Grading and Area Drainage Plan showing all road and lot drainage provisions.
- c) A General Plan showing phasing
- d) A Storm Sewer Drainage Area Plan showing areas, coefficients, hectares.
- e) Plan and Profile Drawings of all streets, service easements and drainage channels and outlets. Plan and profile drawings shall indicate phasing as per the general plan
- f) Plan showing typical road sections, drainage channel sections and servicing details and standards.
- g) Cross-sections of the property and roadways if requested by the Township's Engineer.

The design calculations shall include:

- a) Storm Sewer Design Sheet, and Storm Water Management Facilities Design if applicable.
- b) Design notes on pipe strength and bedding requirements.

- c) Soils Report and road thickness design notes.
- d) Detailed cost estimates of all municipal services to be provided.
- e) Design notes and calculations related to municipal water supply and distribution systems that are to be provided for the development.
- f) An environmental appraisal of the site may be requested by the Township in areas that are particularly sensitive to development.

A "cover sheet" may be included with the contract drawings. However, this requirement is optional and not mandatory.

If a "cover sheet" is provided, the following should be included unless provided elsewhere:

- 1) A key plan, to a scale of not less than 1:10000, indicating the general location of the area to be served.
- 2) A site plan, to a scale of not less than 1:2000, indicating the services to be provided.
- 3) The name of the project, the name and address of the owner and consulting engineer.

#### A.2 General Plans

All General Plans shall:

- a) Be drawn at scale of 1:1250.
- b) Show a key plan (Scale - 1:5000)
- c) Show a north arrow
- d) Show all existing and proposed lot numbers and blocks.
- e) Refer all datum to a bench mark of geodetic origin.
- f) Show all existing services and utilities and abutting property limits in broken lines.

General Plans showing above-ground services shall:

- 1) Show all existing and proposed curbs, road allowances, road widths, street names, catchbasins, manholes, hydrants, road grades.

General Plans showing underground services shall:

- a) Show all existing and proposed sewer lengths, sizes, types, grades (to two decimal points), direction of flow, catchbasins and manholes.
- b) Show all existing and proposed watermain sizes along with valves and hydrants.
- c) Show all house connections, both water, sanitary and storm

A.3 Strip Plans

The strip plans and profiles are to be on plan and profile paper. The scale is to be 1:500 horizontally and 1:50 vertically. The use of 1:100 vertical scale will be permitted if approved by the Township in special cases.

The following are to be shown on the PLAN:

- (a) North arrow (pointing up).
- (b) Show a title block with revision block directly above.
- (c) The sewer and watermain profiles shall be drawn so that each street and easement may be filed separately.
- (d) Refer all datum to a bench mark of geodetic origin.
- (e) Show all existing and proposed lot numbers and blocks.
- (f) Show all existing and proposed curbs, road allowances and street names and indicate them as such.
- (g) Show all existing and proposed watermain sizes, valves, hydrants and other utilities.
- (h) Show all existing and proposed sewer lengths, sizes, types, grades (to two decimal points), direction of flow, catchbasins and manholes.
- (i) Show all house connections, storm, water and sanitary.
- (j) Show all manholes with proper symbols and the sanitary manhole numbers followed by the letter A.
- (k) On all plans and profiles the type of bedding and maximum allowable width of trench if transition width is not used in the pipe strength design, shall be shown along the bottom of the profile.

- l) All manholes and catchbasins shall be referred to an OPSD.
- m) Road stations shall be shown in a plan view at a maximum of 50 metres.
- n) The width of roadway; radii of curvature at street intersections; horizontal alignment main roadway.
- o) Chainages of intersecting streets.
- p) Original ground profile at centreline of roadway.
- q) The centreline of the finished road grade (profile grade, shown by a solid line) and vertical curve details.
- r) Stations and elevations at the beginning and end of vertical curves; grades on the profile; elevations on straight grades between P.I.'s at regular intervals (50m maximum); stations and elevations at centreline of all street intersections.

A.4 Erosion Control Plan

The plan scale is to be 1:500 horizontal and vertical.

The following are to be shown on the plan:

- a) North arrow (pointing up)
- b) Show a title block with revision block directly above
- c) Show silt fence location
- d) Show location of mud mats
- e) Show location of sediment trap
- f) Show temporary overland flow route
- g) Provide notes to cover cleaning of catchbasin, sediment traps and roads
- h) Provide note to maintain silt fence during construction

A.5 Miscellaneous Details

Detail drawings are to show details of special appurtenances, road allowance cross-sections, headwalls, open channel cross-sections, sewer outlet protection and other special structures.

B. SPECIFICATIONS

In general, contract specifications are to be printed on standard 8 1/2" x 11" paper (or metric equivalent). The following colour code should be adopted but is not mandatory:

Information to Tenderers	- Green
Form of Tender	- White
Standard Specifications	- Orange
Special Provisions (Supplementary Specifications)	- Yellow
General Conditions	- Blue

C. AS CONSTRUCTED DRAWINGS

C.1 General

On completion of the work and prior to the assumption of services by the Township, final "as-constructed" drawings will be supplied on a CD in PDF and AutoCad format along with a mylar reproductions of the construction drawings for above and below ground services (plan and profile) and details of special structures as required by the Township are to be submitted to the Township. The scales of these drawings are to be as indicated under SECTION "A".

All lettering and drafting are to be neat and legible, preferably by means of a lettering set.

C.2 Drawing Requirements

The final "as-constructed" drawings are to incorporate all the information as outlined under SECTION "A", with the addition of the following:

- (a) The plans and profiles are to conform to what was actually constructed.
- b) Private drain connections and water services are to have ties and elevations at the street line to the lot lines and benchmarks. This shall be provided in a PDF file for each lot.
- (c) Accuracy of information shown on the drawings are to be within:

\*Ties to services (sewers, watermains, appurtenances, etc.) 300mm (1.00 ft.)

Elevations 15mm (0.05 ft.)

(\*Ties shown to street lines and for lot lines wherever possible).

- (d) Accuracy of plotting is to be within:

Plan 600mm (-2.0 ft.)

Profile 60mm (-0.2 ft.)

Details 40mm (-1.5 in.)

- (e) A note on each plan and profile drawing stating that All elevations related to Contract Bench Mark No: \_\_\_\_\_ Elevation \_\_\_\_\_".



**CHAPTER 8**  
**OTHER STANDARD DRAWINGS**  
**(IN ADDITION TO OPSD)**  
**TABLE OF CONTENTS**

STD-1	Rainfall Intensity Curve (IDF Curves)
STD-2	Standard Road Cross Section Typical Urban Section. 20 R.O.W.
STD-3	Open Channel Sections
STD-4	Driveway Entrance Detail Commercial/Industrial Uses
STD-5	Driveway Entrance Detail Residential (Urban)
STD-6	Driveway Entrance Detail Residential (Rural)
STD-7	Lot Grading Requirements
STD-8	Detail for Storm Connection
STD-9	Plan Legend
STD-10	Pedestrian Barricade Installation
STD-11	Parking Space Requirement

# Short Duration Rainfall Intensity-Duration-Frequency Data

2014/12/21

## Données sur l'intensité, la durée et la fréquence des chutes de pluie de courte durée

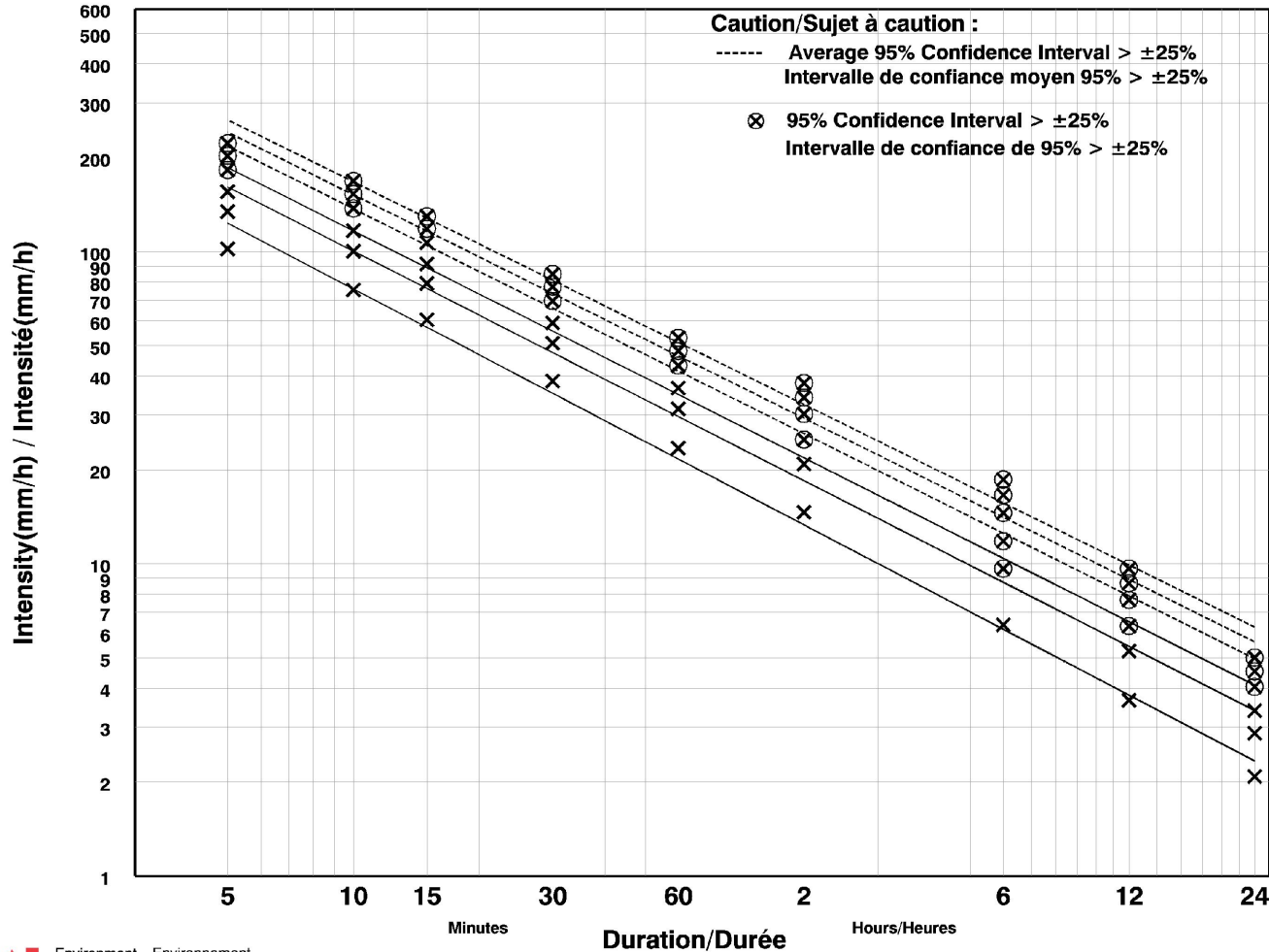

**WOODSTOCK  
ON  
6149625**

**1962 - 2006  
19 years / ans**

**Latitude  
43° 8'N  
Longitude  
80° 46'W**

**Elevation / Altitude  
281 m**

**Return Periods/  
Périodes de retour  
Years / ans**

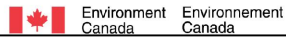

**Woodstock IDF Parameters**

Based on Environment Canada Climate Data - Woodstock Station ID 6149625 (1962 - 2006)

	2 YR	5 YR	10 YR	25 YR	50 YR	100 YR
<b>A</b>	639.965	818.869	958.788	1119.813	1232.834	1353.117
<b>B</b>	5.334	5.616	6.029	6.178	6.238	6.361
<b>C</b>	0.785	0.768	0.764	0.759	0.755	0.753

TOWNSHIP OF  
**BLANDFORD-BLENHEIM**

**RAINFALL INTENSITY  
CURVE**

SCALE: N.T.S.  
DATE: March 2016

**STD - 1**

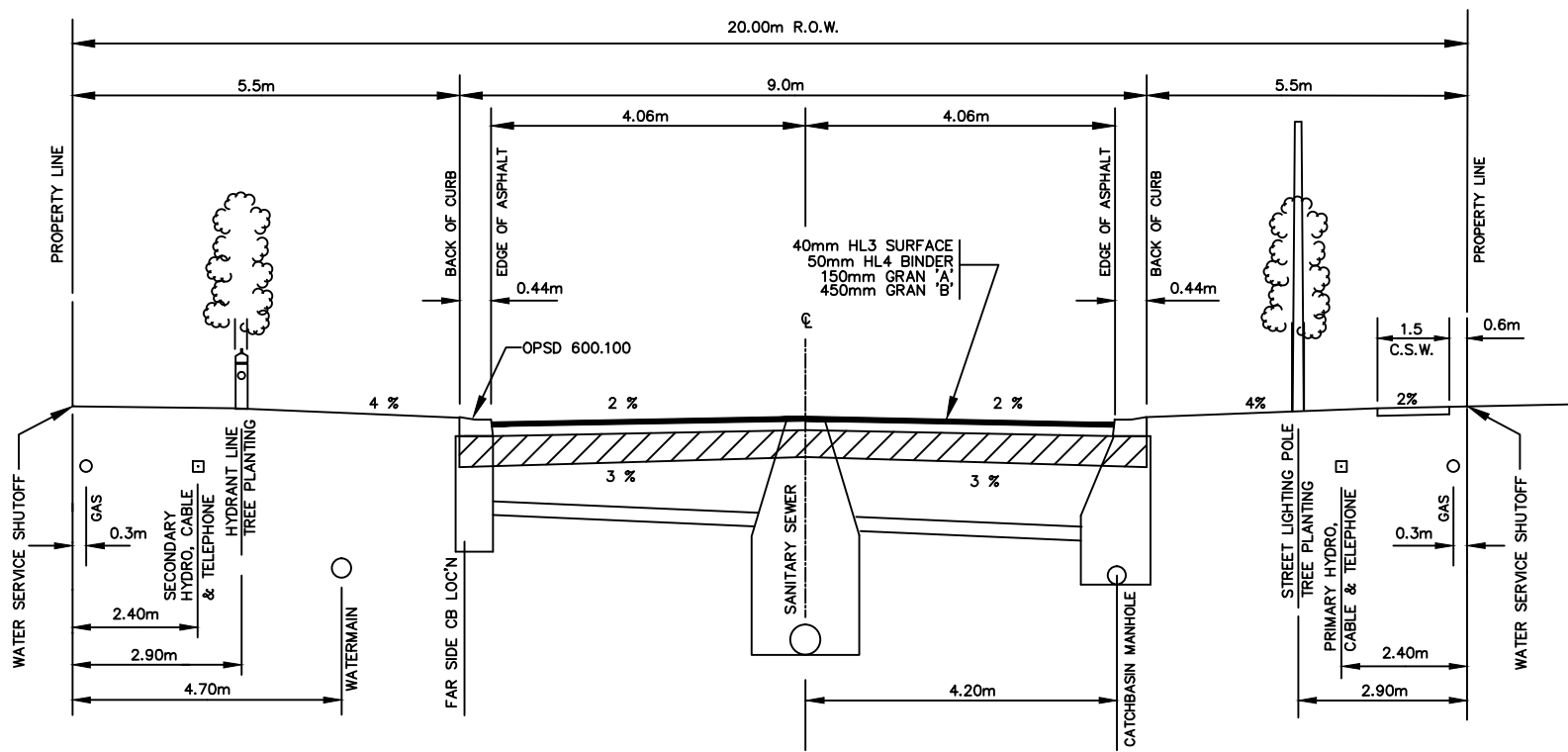

**MINIMUM COVER**

SANITARY	2.8m
STORM	1.5m
WATERMAIN	1.8m
GAS	0.8m
BELL	0.8m
HYDRO	0.8m
CABLE	0.8m

**STANDARD STREET CROSS-SECTION**

N.T.S.

**NOTES**

1. BOULEVARDS TO BE TOPSOILD AND SODDED, SLOPES 2% MIN. 8% MAX.
2. GRANULAR BASE TO BE CONFIRMED BY SOILS REPORT.
3. MINIMUM ROAD GRADE 0.5%
4. MAXIMUM ROAD GRADE 0.5%
5. TREES TO BE PLANTED EVERY 20m ALONG BOTH SIDES OF ALL ROAD ALLOWANCES WHERE REQUIRED.
6. ALL HYDRO, BELL AND OTHER UTILITIES TO BE UNDERGROUND.
7. CONCRETE SIDEWALK TO BE PROVIDED ON ONE SIDE OF ALL ROAD ALLOWANCES.
8. THIS STANDARD IS TO BE READ IN CONJUNCTION WITH OPSD 217.01. BUT IT APPLIES IF IN CONFLICT WITH OPSD 217.01.
9. TREE PLANTING TO BE APPROVED BY TOWNSHIP.

TOWNSHIP OF <b>BLANDFORD-BLENHEIM</b>	
<b>STANDARD ROAD CROSS SECTION TYPICAL URBAN SECTION. 20m R.O.W.</b>	
SCALE:	<b>STD - 2</b>
DATE: MARCH 2016	

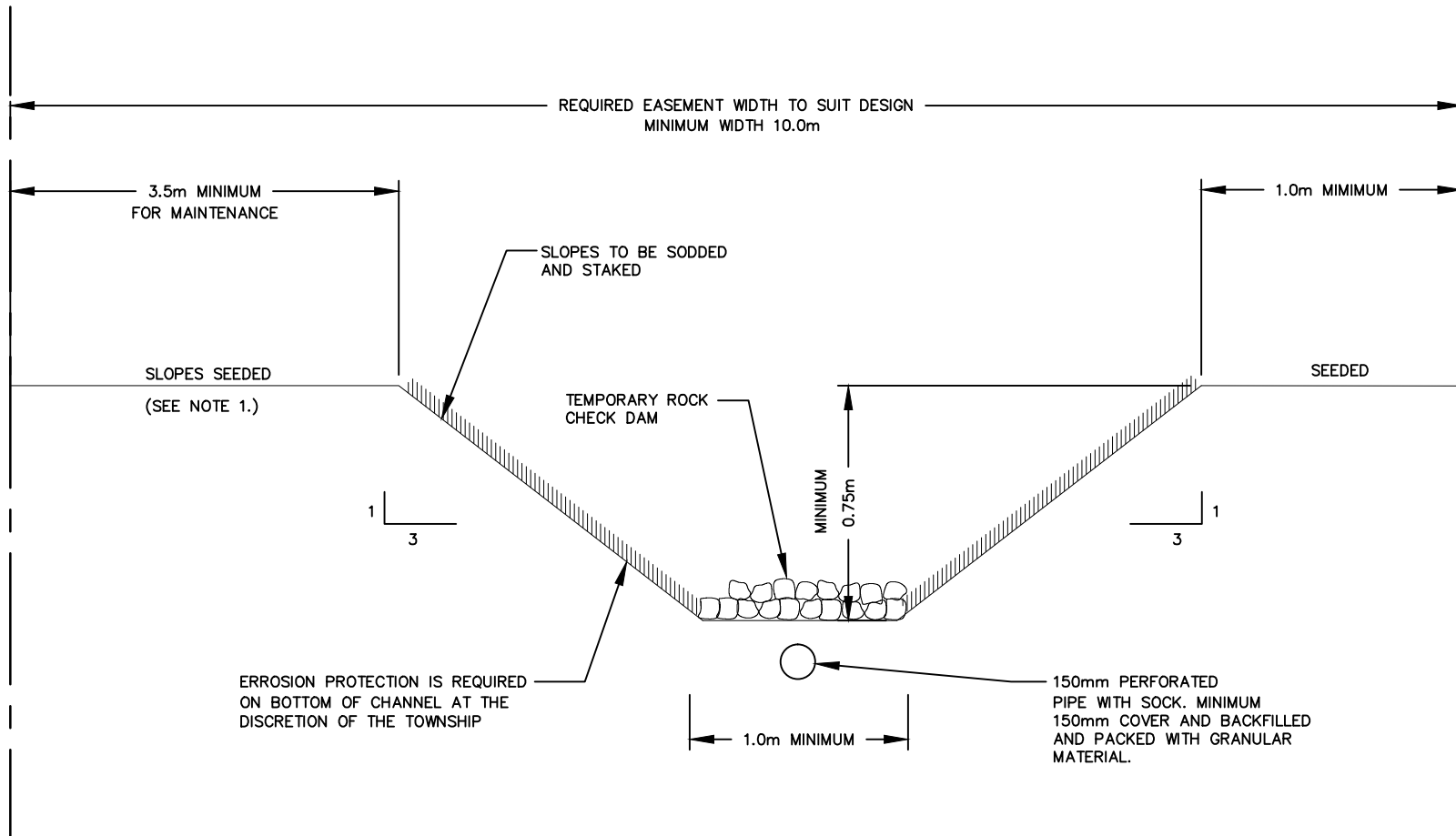

NOTES:

1. SLOPES ON BOTH SIDES OF THE DITCH TO BE MINIMUM 1% AND MAXIMUM 4%.

TOWNSHIP OF <b>BLANDFORD-BLENHEIM</b>	
<b>OPEN CHANNEL SECTIONS</b>	
SCALE: N.T.S.	<b>STD - 3</b>
DATE: MARCH 2016	

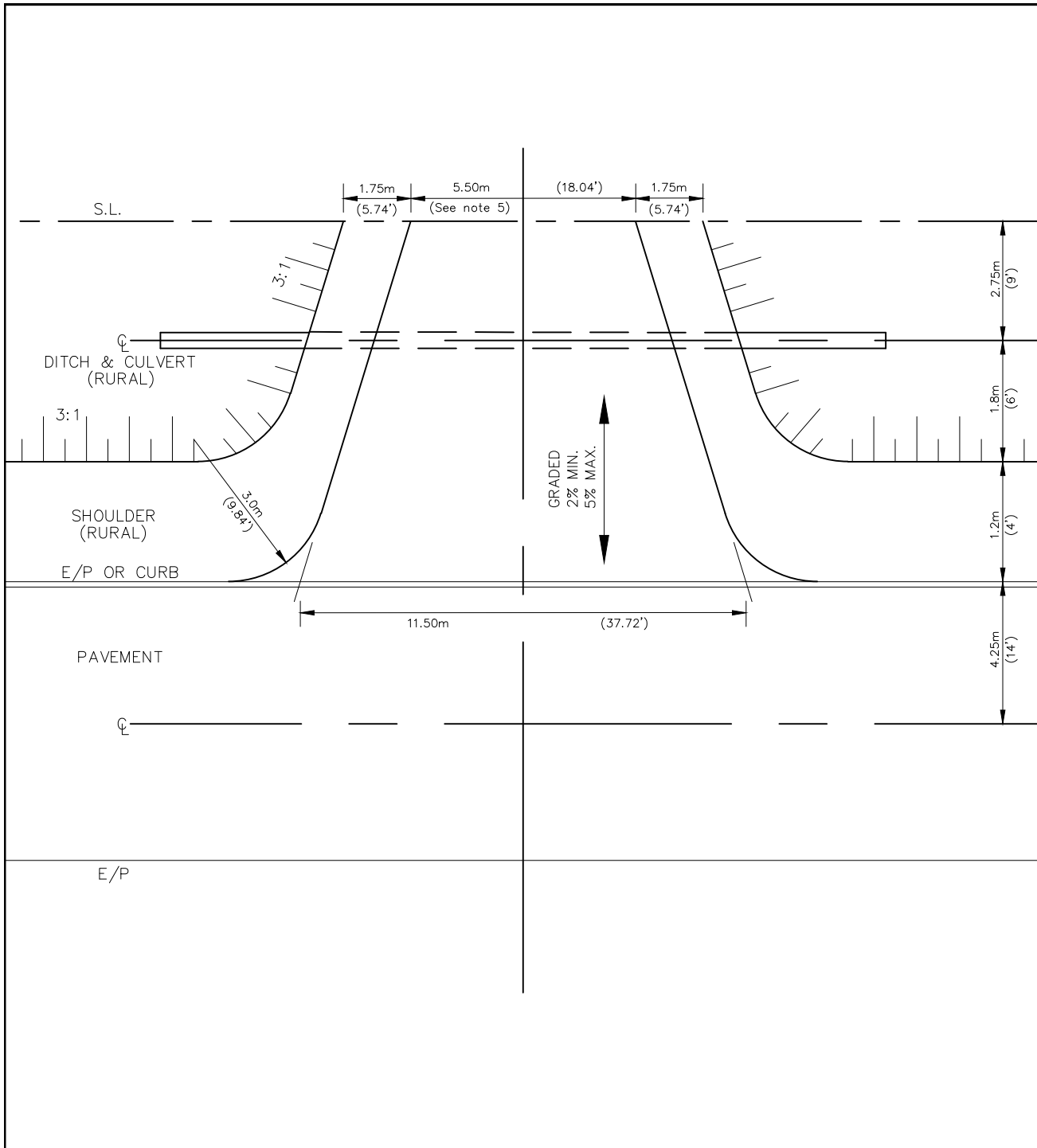

**NOTES**

1. DRIVEWAY CROSS-SECTION TO BE  
 80mm (3.2") ASPHALT | 35mm (1 3/8") SURFACE  
 45mm (1 3/4") BINDER  
 150mm (6") GRANULAR 'A'  
 300mm (12") GRANULAR 'B'
2. DRIVEWAY CULVERTS IF ANY TO BE 400mm (16") DIAMETER CMP MINIMUM, 1% SLOPE AND MINIMUM 0.30m (1') COVER.
3. MINIMUM LENGTH OF CULVERT TO BE 17.5m (57.4')
4. INCREASE TO THE ABOVE MINIMUM STANDARDS TO BE APPROVED BY THE TOWNSHIP ENGINEER.
5. FOR DRIVEWAY OFF COUNTY ROAD REFER TO COUNTY OF OXFORD DEVELOPMENT STANDARDS.

TOWNSHIP OF <b>BLANDFORD-BLENHEIM</b>	
<b>DRIVEWAY ENTRANCE DETAIL COMMERCIAL / INDUSTRIAL USES</b>	
SCALE: N.T.S.	<b>STD - 4</b>
DATE: MARCH 2016	

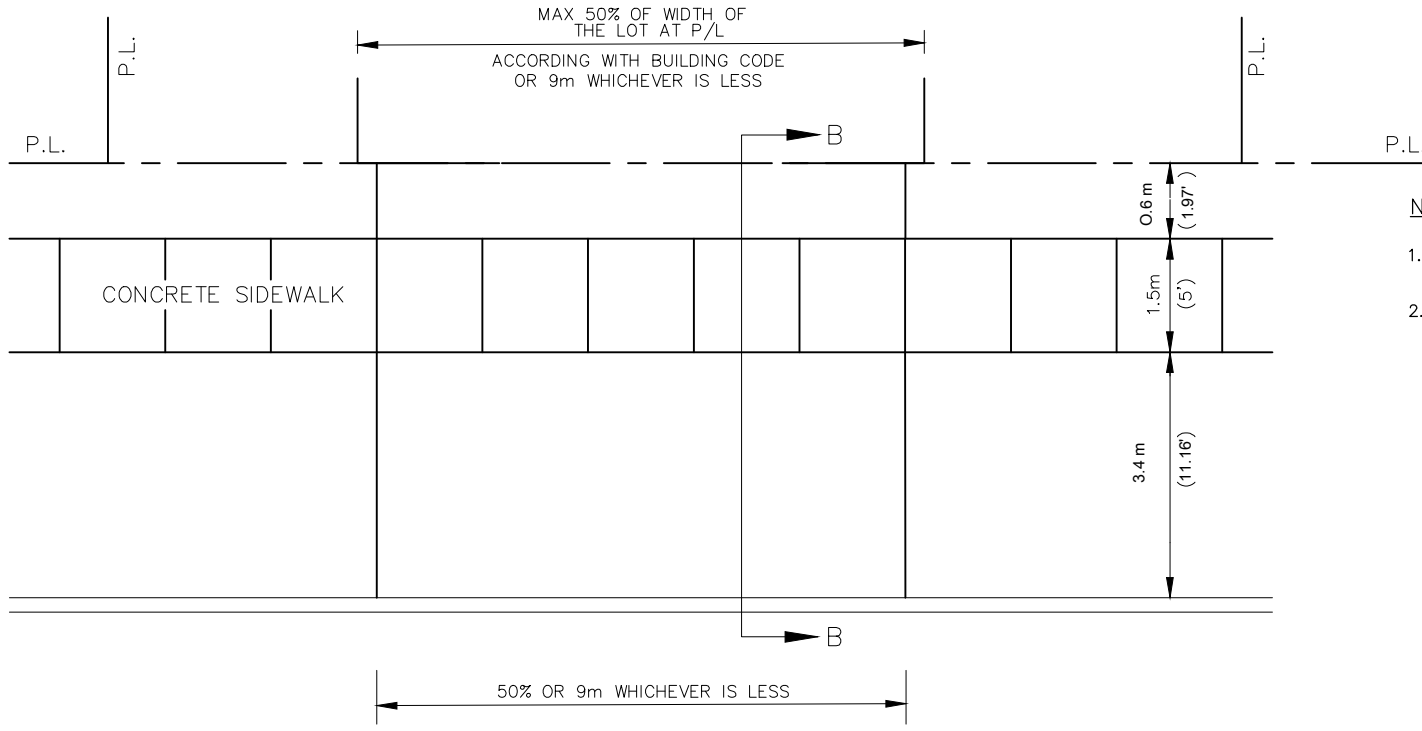

**NOTES**

1. ALL DRIVEWAYS ARE TO BE ASPHALTED TO THE STREET LINE.
2. MAXIMUM DRIVEWAY PAVEMENT WIDTH TO BE 50% OF WIDTH OF THE LOT AT PROPERTY LINE OR 9m, WHICHEVER IS LESS.

**PLAN**  
NTS

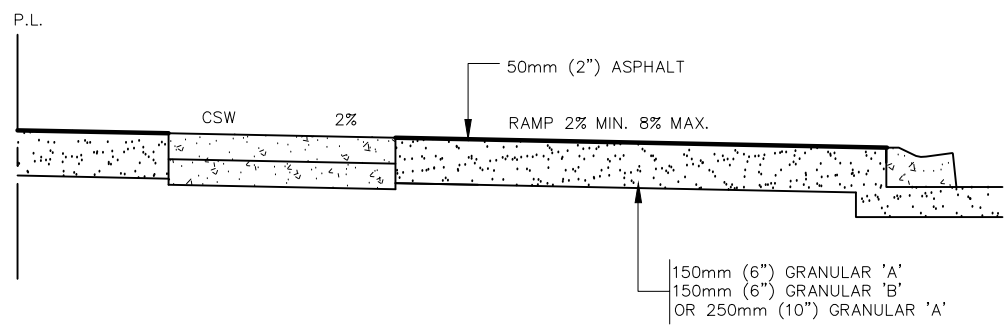

**SECTION B-B**  
1:50

TOWNSHIP OF <b>BLANDFORD-BLENHEIM</b>	
<b>DRIVEWAY ENTRANCE DETAIL RESIDENTIAL (URBAN)</b>	
SCALE: AS SHOWN	<b>STD - 5</b>
DATE: MARCH 2016	

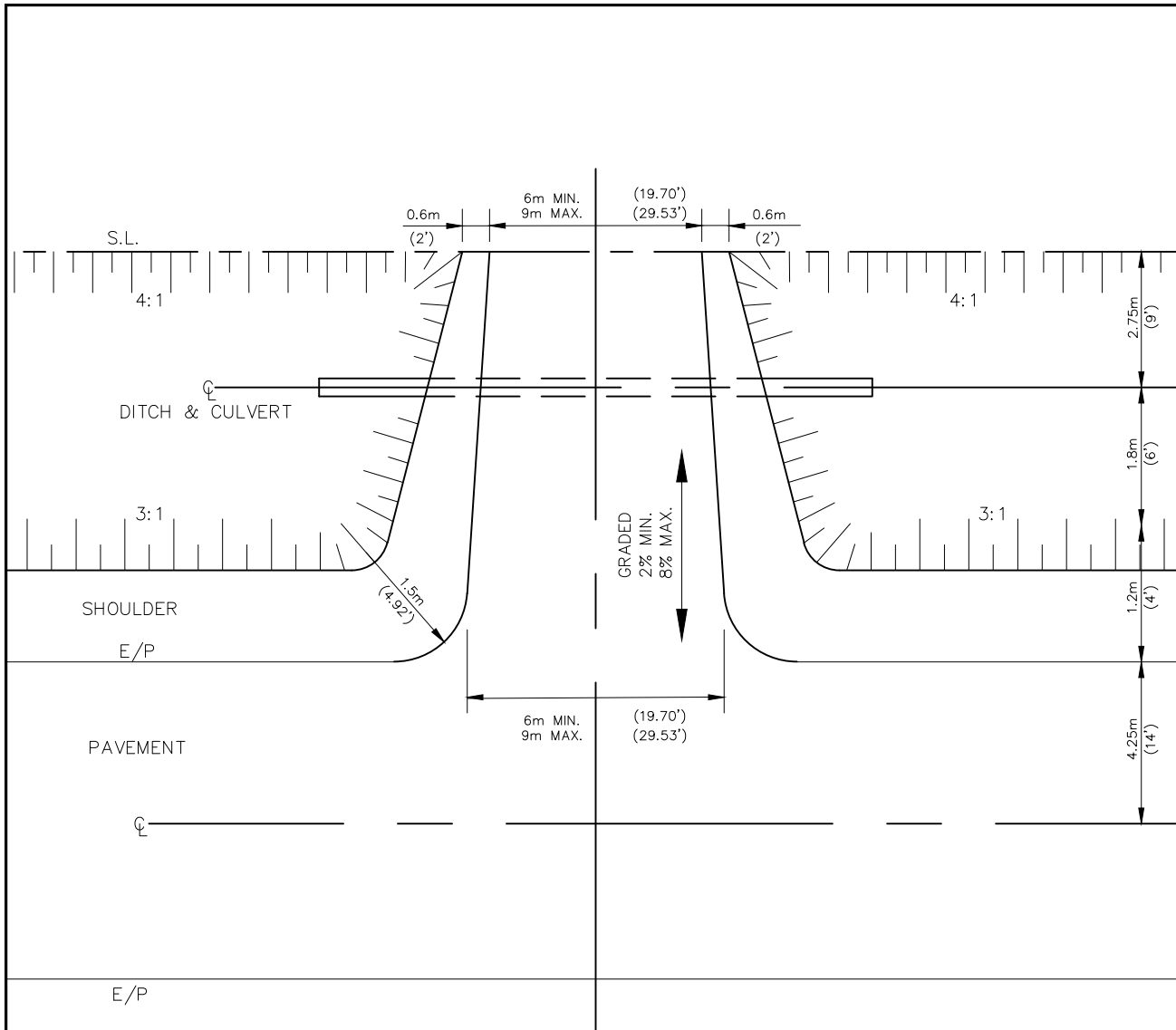

**NOTES**

1. DRIVEWAY CROSS-SECTION TO BE  
 50mm (2") ASPHALT  
 150mm (6") GRANULAR 'A'  
 150mm (6") GRANULAR 'B'
2. DRIVEWAY CULVERTS TO BE 400mm (16") DIAMETER CMP MINIMUM, 1% SLOPE AND MINIMUM 0.30m (1') COVER AND SET 50mm BELOW DITCH GRADES.
3. MINIMUM LENGTH OF CULVERT TO BE 12m (39')
4. FOR DOUBLE DRIVEWAY AND/OR DRIVEWAY OFF A COUNTY ROAD, PAVEMENT WIDTH TO BE AT STREET LINE 6.00m (19.69'), AT EDGE OF PAVEMENT 7.50m (24.60') AND GRAVEL SHOULDERS TO REMAIN THE SAME. CULVERT LENGTHS TO BE 14m (45.90')
5. INCREASE TO THE ABOVE MINIMUM STANDARDS TO BE APPROVED BY THE TOWNSHIP ENGINEER.

**DETAIL FOR SINGLE DRIVEWAY**

TOWNSHIP OF <b>BLANDFORD-BLENHEIM</b>	
<b>DRIVEWAY ENTRANCE DETAIL RESIDENTIAL (RURAL)</b>	
SCALE: N.T.S.	<b>STD - 6</b>
DATE: MARCH 2016	

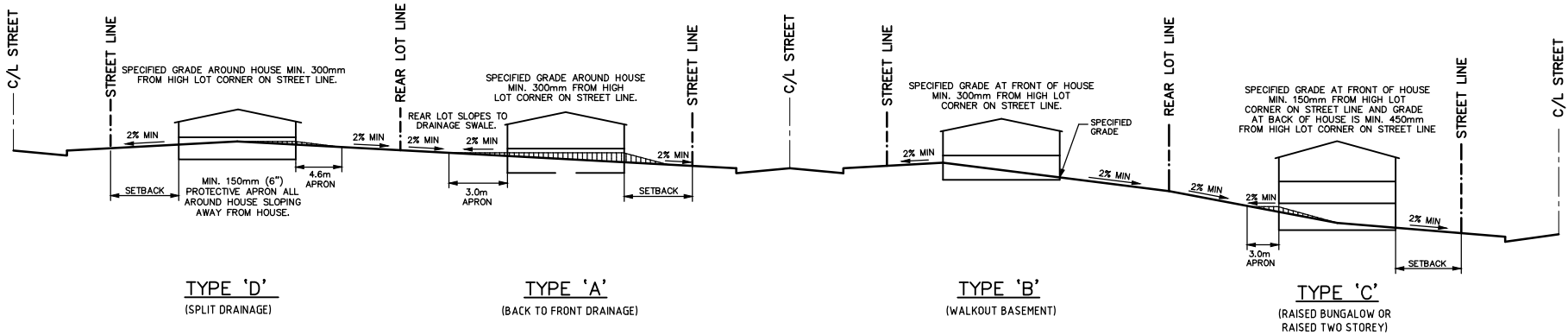

**TYPE 'D'**  
(SPLIT DRAINAGE)

**TYPE 'A'**  
(BACK TO FRONT DRAINAGE)

**TYPE 'B'**  
(WALKOUT BASEMENT)

**TYPE 'C'**  
(RAISED BUNGALOW OR RAISED TWO STOREY)

LOCATION OF FLOW DIVISION LINE VARIES WITH ROAD GRADE. BREAK POINT ALONG REAR PROPERTY LINE IF ELEV SHOWN ON GRADING PLANS. FLOW TO BE CARRIED AROUND HOUSE IN DEFINED SWALE LOCATED BESIDE LOT LINE. BREAK POINT ALONG REAR PROPERTY LINE IF ELEV SHOWN ON GRADING PLANS.

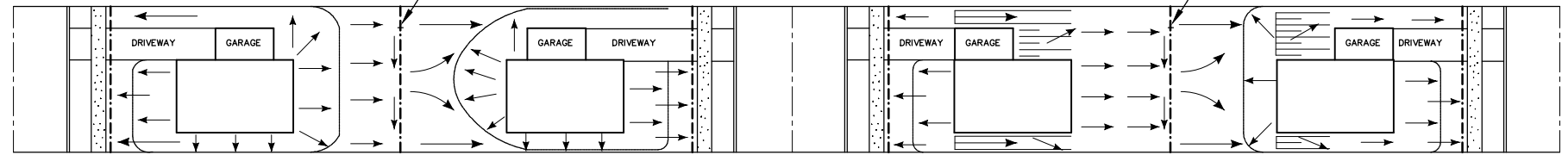

**TYPE D**

**TYPE A**

**TYPE B**

**TYPE C**

**TYPICAL PLAN VIEW DRAINAGE**  
N.T.S.

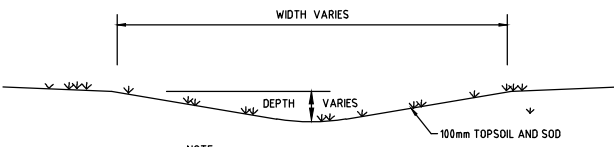

**NOTE:**  
OPTIMUM SIDE SLOPE - 1 VERTICAL TO 6 HORIZONTAL  
MAXIMUM SIDE SLOPE - 1 VERTICAL TO 3 HORIZONTAL  
MINIMUM GRADIENT - 2.0%  
MAXIMUM GRADIENT - 10%  
GRADE TRANSITIONS SHALL BE SMOOTH TO FACILITATE THE MOWING OPERATION

**TYPICAL SECTION OF GRASS SWALE USED IN LOT GRADING**  
N.T.S.

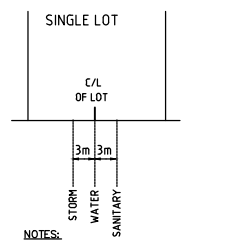

**NOTES:**  
1. PROVIDE 50mm X 100mm MARKERS FOR SANITARY (RED), WATER (BLUE) AND STORM (GREEN)

**TYPICAL LOT SERVICING**  
N.T.S.

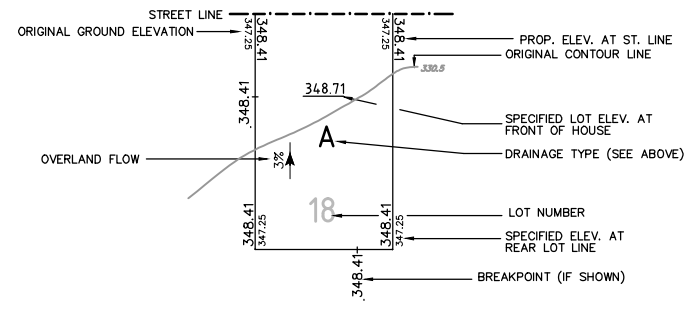

**TYPICAL LOT GRADING**  
N.T.S.

**DRAINAGE NOTES**

- SURFACE DRAINAGE SHALL BE DIRECTED AWAY FROM HOUSES.
- DOWNSPITS TO BE DIRECTED AWAY FROM HOUSES TO LAWN.
- SURFACE DRAINAGE WHICH IS CARRIED AROUND HOUSES IS TO BE CONFINED IN SWALES LOCATED AS FAR FROM THE HOUSE AS POSSIBLE (SEE SWALE CROSS SECTION).
- DRIVEWAYS:
  - OPTIMUM GRADIENT 4%
  - MAXIMUM CROSS SLOPE 6%
  - MINIMUM CROSS SLOPE 2%
  - (WHERE GRADIENT IS LESS THAN 2%)
  - MAXIMUM GRADIENT 8%
- WALKWAYS:
  - MAXIMUM GRADIENT AND CROSS SLOPE 6%
  - MINIMUM GRADIENT CROSS SLOPE 2%
  - (WHERE GRADIENT IS LESS THAN 2%)
- FROM HOUSE TO LOT LINE (ALWAYS AWAY FROM HOUSE)
  - MINIMUM SLOPE 2%
  - OPTIMUM SLOPE 4%
  - MINIMUM DIFFERENCE 0.15m
- ELSEWHERE ON THE SITE
  - OPTIMUM GRADIENT 4%
  - MINIMUM GRADIENT 2%

**GENERAL NOTES**

- THE TOPOGRAPHY AND LOT ELEVATIONS INDICATED ON THESE PLANS ARE SUPPLIED FOR THE BUILDER'S INFORMATION ONLY. IT SHALL BE THE BUILDER'S RESPONSIBILITY TO VERIFY THE ACCURACY OF ALL INFORMATION OBTAINED BY HIM FROM THESE PLANS.
- DRAINAGE SWALES SHALL BE CONSTRUCTED IN THE LOCATIONS AND TO THE GRADES, DEPTHS AND SECTIONS SPECIFIED.
- SURVEY MONUMENTS ARE TO BE PROTECTED, NOTIFY ENGINEER BEFORE DISTURBING ANY BENCHMARKS OR CONTROL POINTS.
- ANY VARIATION IN THE LOT GRADING STANDARDS MUST BE APPROVED BY A TOWNSHIP ENGINEER.

TOWNSHIP OF <b>BLANDFORD-BLENHEIM</b>	
<b>LOT GRADING REQUIREMENTS</b>	
SCALE: N.T.S.	<b>STD - 7</b>
DATE: MARCH 2016	



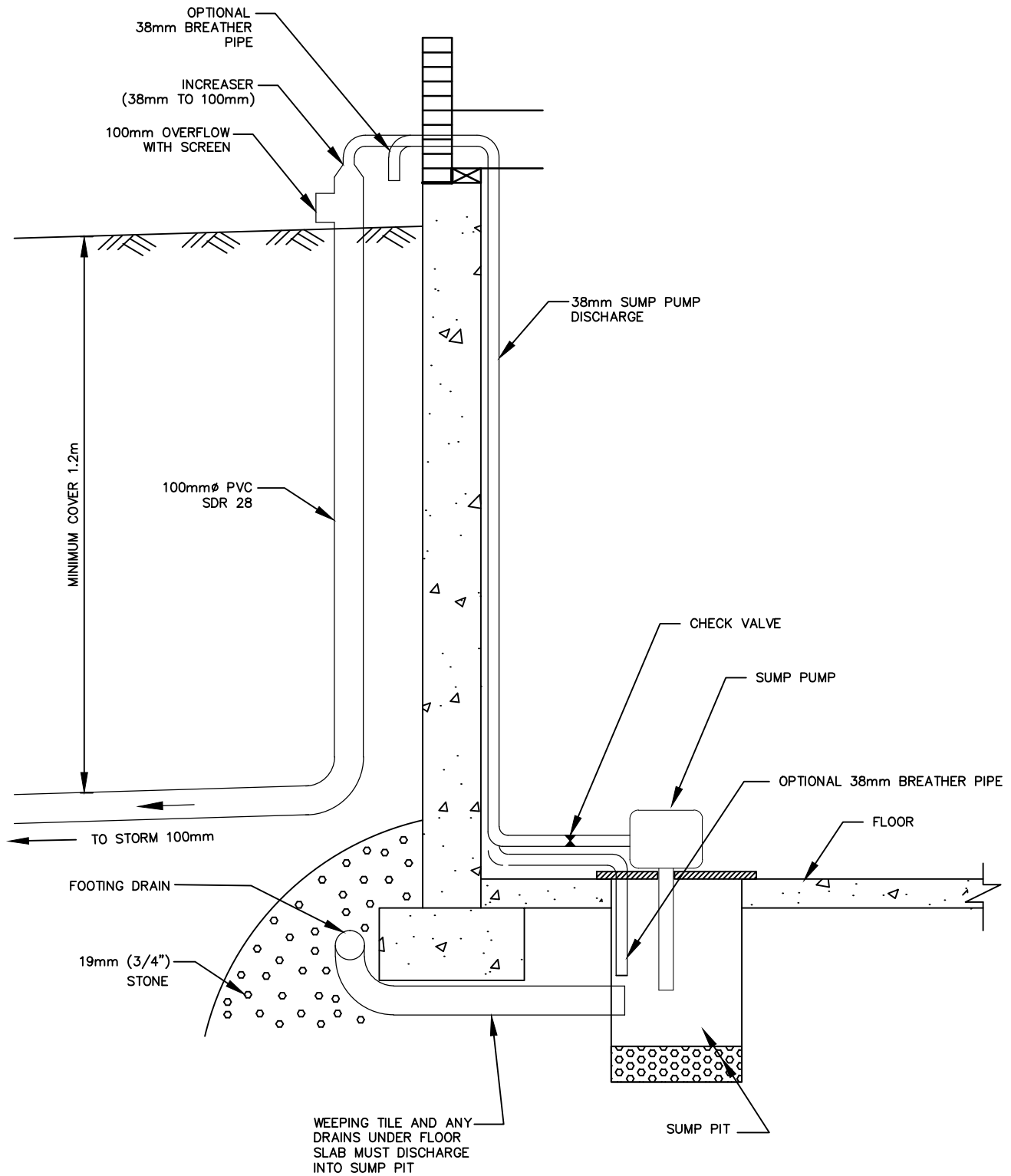

**NOTES**

1. A SEPARATE BUT PARALLELING 38mm DIA BREATHER PIPE FROM THE SUMP PUMP PIT MAY BE DESIRABLE.

TOWNSHIP OF <b>BLANDFORD-BLENHEIM</b>	
<b>DETAIL FOR STORM CONNECTION</b>	
SCALE : 1:20	<b>STD - 8</b>
DATE: MARCH 2016	

F.F. DENOTES FINISHED FLOOR  
 T.F. DENOTES TOP OF FOUNDATION

x 306.00 EXISTING ELEVATION

 EXISTING GROUND CONTOUR ELEVATION

**306.00** PROPOSED ELEVATION

**MATCH EST. 305.9** MATCH EXISTING GROUND ELEVATION AT PROPERTY LINE EST = ESTIMATED

 DIRECTION OF SURFACE FLOW

 PROPOSED SURFACE SWALE

 LOCATION OF PUMP DISCHARGE

 WATER SERVICE

 SANITARY SEWER SERVICE

 ZONING SETBACK LIMITS

 MAJOR STORM ROUTE

 HYDRANT SET

   PROPERTY BARS

 BENCHMARKS

 SURVEY CONTROL POINTS

 PROPOSED STORM

 MH20 STORM MANHOLE

 CBMH17 STORM CATCHBASIN MANHOLE

 CBMH32 STORM TWIN CBMH

 CB 25 STORM SINGLE CATCHBASIN (250mm LEAD)

 CB 33 STORM TWIN CATCHBASIN (300mm LEAD)

 EXISTING STORM

 EXISTING SANITARY

 EXISTING SANITARY FORCEMAIN

 EXISTING WATERMAIN, WATER VALVE AND FIRE HYDRANT

 EXISTING U/G GAS AND VALVE

 EXISTING U/G BELL AND BELL BOX

 UTILITY POLES ( BELL, HYDRO )

TOWNSHIP OF <b>BLANDFORD-BLENHEIM</b>	
<b>PLAN LEGEND</b>	
SCALE:	<b>STD - 9</b>
DATE: APRIL 2006	

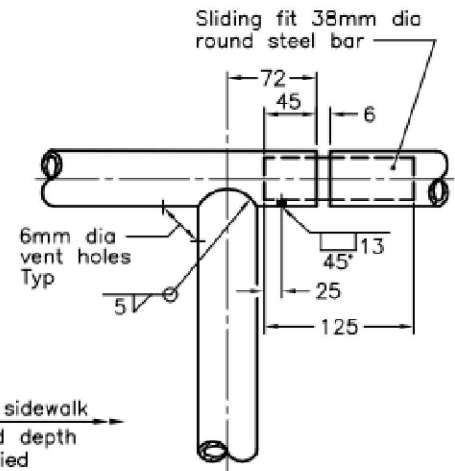
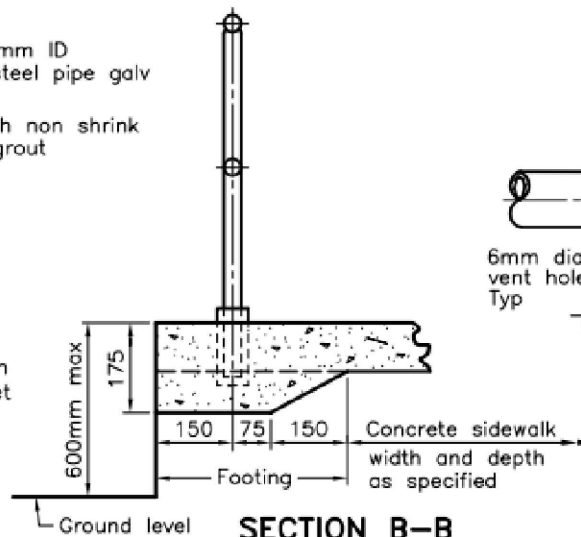
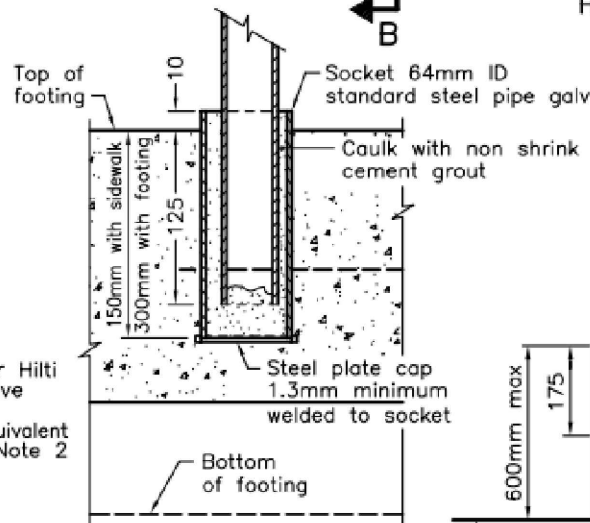
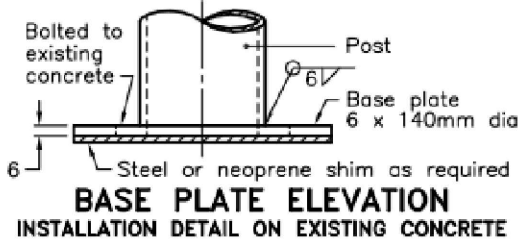
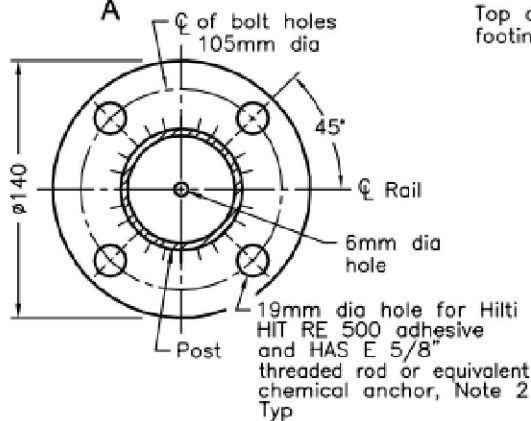
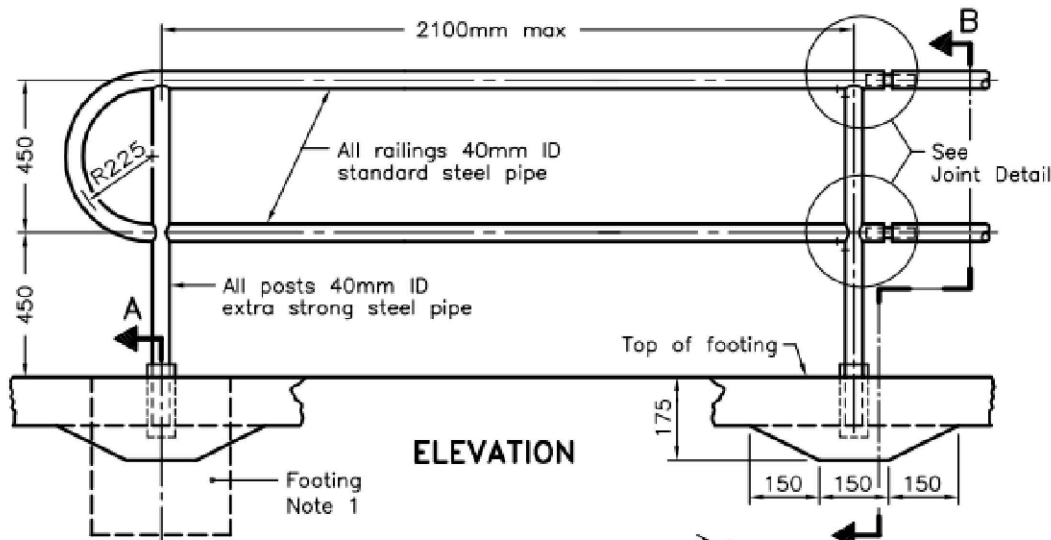

**NOTES:**

- 1 When sidewalk is not specified, posts shall be set in centre of 300mm dia x 450mm deep or 300 x 300 x 375mm deep concrete footings.
  - 2 Anchors shall be installed according to manufacturer's specifications.
- A Concrete shall have a nominal minimum 28-Day compressive strength of 20MPa.
- B Posts and railings shall be hot dip galvanized according to CSA G164 after fabrication.
- C Posts shall be vertical. All exposed corners shall be ground smooth.
- D Welding shall be according to CSA W59.
- E All joints shall be shop welded.
- F Pipe shall be according to ASTM A 53.
- G A difference in elevation between the adjacent ground level and top of footing shall not exceed 600mm.
- H All dimensions are in millimetres unless otherwise shown.

TOWNSHIP OF  
**BLANDFORD-BLENHEIM**

**PEDESTRIAN BARRICADE  
INSTALLATION  
PER OPSD 980.101**

SCALE: NTS  
DATE: MARCH 2016

**STD - 10**

**30 DEGREE ANGLE**

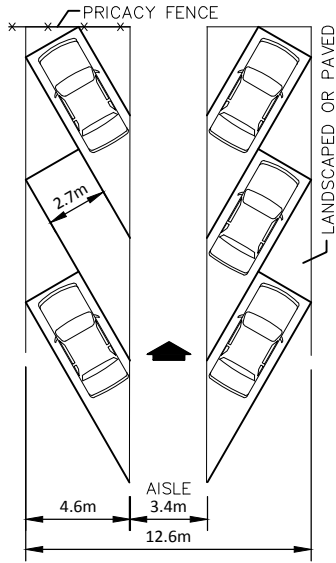

**45 DEGREE ANGLE**

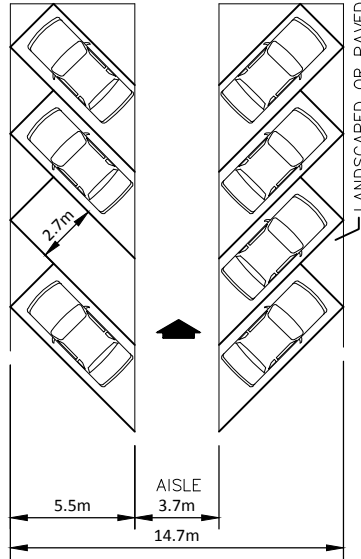

**55 DEGREE ANGLE**

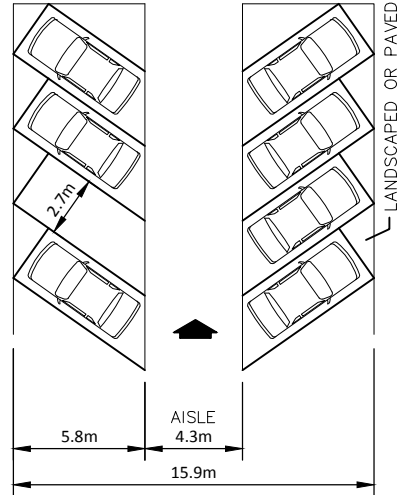

**60 DEGREE ANGLE**

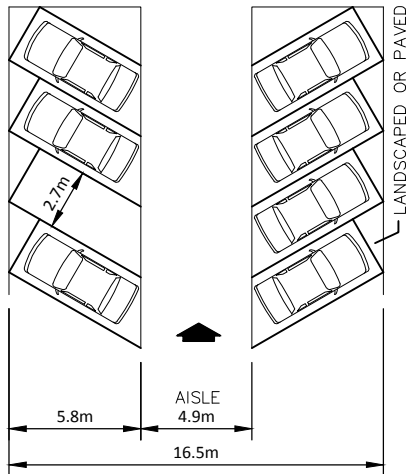

**65 DEGREE ANGLE**

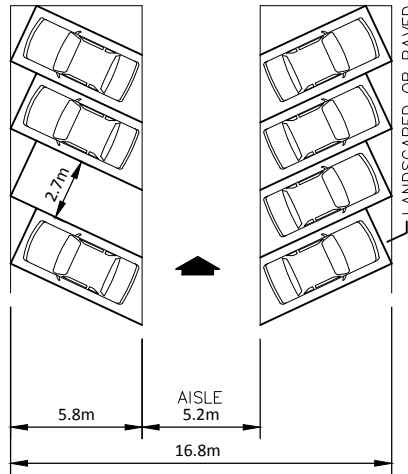

**70 DEGREE ANGLE**

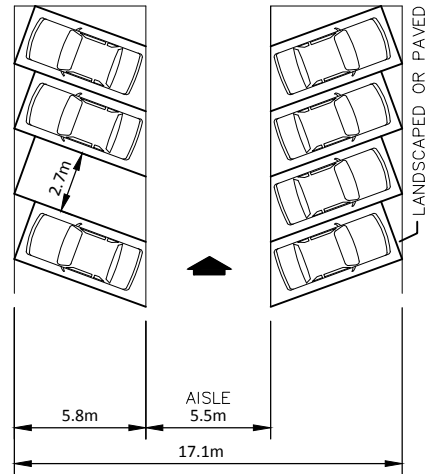

**90 DEGREE ANGLE**

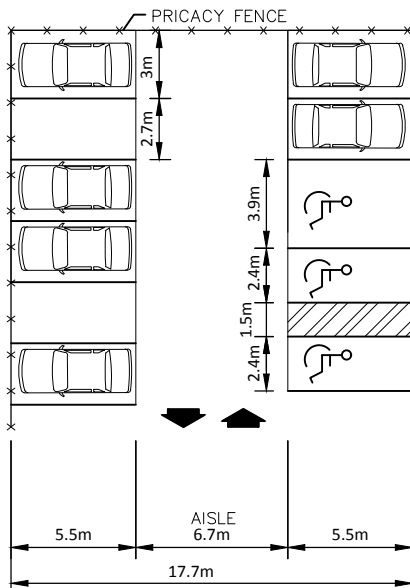

**PARALLEL**

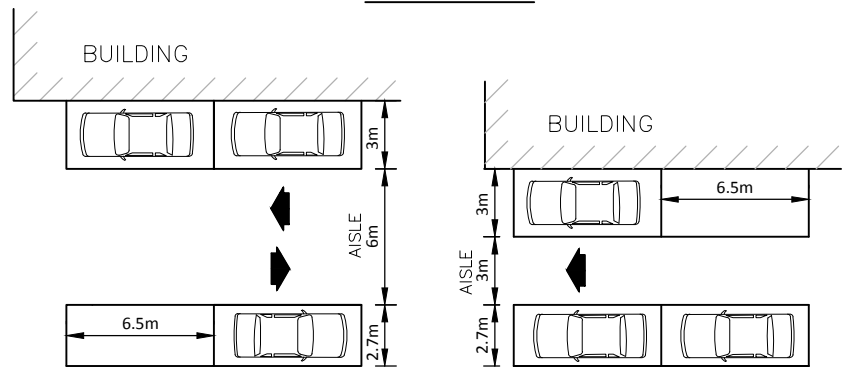

TOWNSHIP OF <b>BLANDFORD-BLENHEIM</b>	
<b>PARKING SPACE REQUIREMENT</b> BY CONFIGURATION	
SCALE : NTS	<b>STD - 11</b>
DATE: MARCH 2016	

**APPENDIX A**  
**RECOMMENDED STREET LIGHTING**

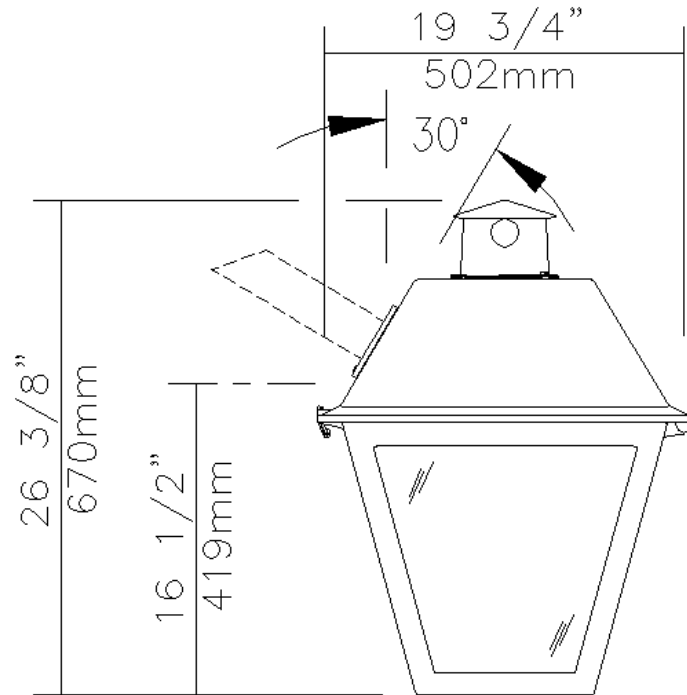
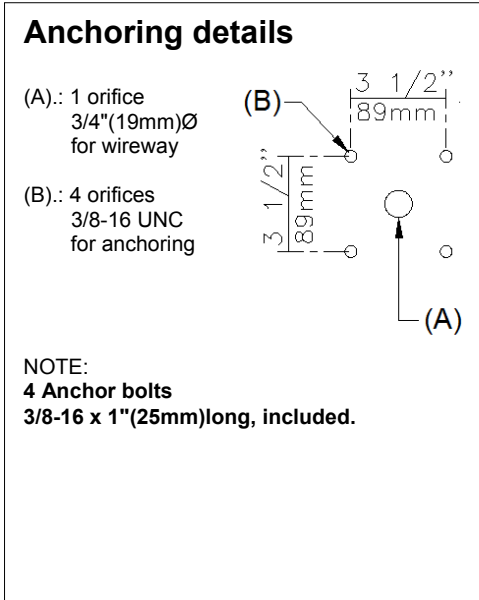

EPA: 2.74 sq ft / weight: 50 lb (22.7 kg)

Qty	1	Luminaire	L40U-STM-80W48LED4K-R-ACDR-C-LE3-120-RC-BKTX
-----	---	-----------	--

**Description of Components:**

**Cupola:** Decorative cast 356 aluminum photocell housing, c/w a window, mechanically mounted on hood.

**Hood:** In a square tapered shape, the hood is made of one-piece die cast injection molded A360 aluminium. Mechanically assembled to the guard complete with a surface for anchoring.

**Guard:** In a square tapered shape, the guard is made of one-piece die cast injection molded A360 aluminium.

**Access-Mechanism:** Two integrated hinges on the hood with a stopper and a latch shall offer a tool-free access to the inside of the luminaire. An embedded memory-retentive gasket shall ensure weatherproofing.

**Light Engine: LEDgine** composed of 4 main components: **Heat Sink / LED Module / Optical System / Driver**  
Electrical components are RoHS compliant.

**Heat Sink:** Made of cast aluminum optimising the LEDs efficiency and life. Product does not use any cooling device with moving parts (only passive cooling device).

**Globe:** (ACDR-C), Made of one-piece seamless injection-molded clear impact-resistant (DR) acrylic. The globe is assembled on the access-mechanism.

**LED Module:** LED type Philips Lumileds LUXEON R. Composed of 48 high-performance white LEDs. Color temperature as per ANSI/NEMA bin Neutral White, 4000 Kelvin nominal (3985K +/- 275K or 3710K to 4260K), CRI 70 Min. 75 Typical.

**Optical System:** (LE3), IES type III (asymmetrical). Composed of high-performance optical grade PMMA acrylic refractor lenses to achieve desired distribution optimized to get maximum spacing, target lumens and a superior lighting uniformity. Optical system is rated IP66. Performance shall be tested per LM-63, LM-79 and TM-15 (IESNA) certifying its photometric performance. Street side indicated.

**Driver:** High power factor of 90% minimum. Electronic driver, operating range 50/60 Hz. **Auto-adjusting universal voltage input from 120 to 277 VAC rated for both application line to line or line to neutral, Class I**, THD of 20% max. Maximum ambient operating temperature from -40F(-40C) to 130F(55C) degrees.

□

The current supplying the LEDs will be reduced by the driver if the driver experiences internal overheating as a protection to the LEDs and the electrical components. Output is protected from short circuits, voltage overload and current overload. Automatic recovery after correction. Standard built-in driver surge protection of 2.5kV (min).

**Surge Protector:** Surge protector tested in accordance with ANSI/IEEE C62.45 per ANSI/IEEE C62.41.2 Scenario I Category C High Exposure 10kV/10kA waveforms for Line-Ground, Line-Neutral and Neutral-Ground, and in accordance with U.S. DOE (Department of Energy) MSSLC (Municipal Solid-State Street Lighting Consortium) model specification for LED roadway luminaires electrical immunity requirements for High Test Level 10kV / 10kA.

**Luminaire Options: (RC)**, Receptacle for a twist-lock photoelectric cell or a shorting cap. Use of photocell or shorting cap is required to ensure proper illumination.

**IMPORTANT NOTE: Please note that this is a side mounted fixture.**

Miscellaneous

**Description of Components:**

**Wiring:** Luminaire wiring is done using a connector block.

**Hardware:** All exposed screws shall be complete with Ceramic primer-seal basecoat to reduce seizing of the parts and offers a high resistance to corrosion. All seals and sealing devices are made and/or lined with EPDM and/or silicone and/or rubber.

**Finish:** Color to be **black textured RAL9005TX (BKTX)** and in accordance with the AAMA 2603 standard. Application of polyester powder coat paint (4 mils/100 microns) with  $\pm 1$  mils/24 microns of tolerance. The Thermosetting resins provides a discoloration resistant finish in accordance with the ASTM D2244 standard, as well as luster retention in keeping with the ASTM D523 standard and humidity proof in accordance with the ASTM D2247 standard.

The surface treatment achieves a minimum of 2000 hours for salt spray resistant finish in accordance with testing performed and per ASTM B117 standard.

**LED products manufacturing standard:** The electronic components sensitive to electrostatic discharge (ESD) such as light emitting diodes (LEDs) are assembled in compliance with IEC61340-5-1 and ANSI/ESD S20.20 standards so as to eliminate ESD events that could decrease the useful life of the product.

**Quality Control:** The manufacturer must provide a written confirmation of its ISO 9001-2008 and ISO 14001-2004 International Quality Standards Certification.

**Web site information details:** Click on any specific information details you need:

[Paint finish](#) / [Warranties](#) / [ISO 9001-2008 Certification](#) / [ISO 14001-2004 Certification](#)





LEDGINE

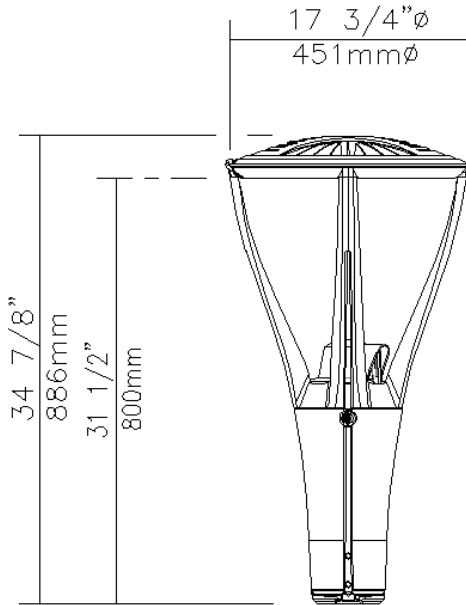

EPA: 1.698 sq ft / weight: 32.2 lb (14.6 kg)

Note: 3D image may not represent color or option selected.  
Logos above include link, click to access.

Qty	1	Luminaire	MPTC-55W48LED4K-T-LE3-UNIV-RCD-NP
-----	---	-----------	-----------------------------------

**Description of Components:**

**Hood:** Made of die cast A360.1 Aluminum alloy 0.100 (2.5mm) minimum thickness, mechanically assembled to the cast aluminum heat sink.

**Guard:** In a round shape with 4 arms and a built-in mechanical ring, this guard is a one piece die cast A360 Aluminum alloy 0.100 (2.5mm) minimum thickness, mechanically assembled to the fitter.

**Access-Mechanism:** A die cast A360.1 Aluminum alloy 0.100 (2.5mm) minimum thickness technical ring with latch and hinge.

**Light Engine: LEDgine** composed of 4 main components: **Heat Sink / LED Module / Optical System / Driver**  
Electrical components are RoHS compliant. Maximum ambient operating temperature up to 40C(104F) degrees.

**Heat Sink:** Made of cast aluminum optimising the LEDs efficiency and life. Product does not use any cooling device with moving parts (only passive cooling device).

**Lens:** Made of soda-lime tempered glass lens, mechanically assembled and sealed onto the ring of the access mechanism.

**LED Module:** LED type Philips Lumileds LUXEON T. Composed of 48 high-performance white LEDs. Color temperature as per ANSI/NEMA bin Neutral White, 4000 Kelvin nominal (3985K +/- 275K or 3710K to 4260K), CRI 70 Min. 75 Typical.

**Optical System:** (LE3), IES type III (asymmetrical). Composed of high-performance optical polymer refractor lenses to achieve desired distribution optimized to get maximum spacing, target lumens and a superior lighting uniformity. System is rated IP66. Performance shall be tested per LM-63, LM-79 and TM-15 (IESNA) certifying its photometric performance. Street

side indicated. Dark Sky compliant with 0% uplight and U0 per IESNA TM-15.

**Driver:** High power factor of 90% minimum. Electronic driver, operating range 50/60 Hz. **Auto-adjusting universal voltage input from 120 to 277 VAC rated for both application line to line or line to neutral, Class I**, THD of 20% max. Maximum ambient operating temperature from -40F(-40C) to 130F(55C) degrees. Assembled on a unitized removable tray with Tyco quick disconnect plug resisting to 221F(105C) degrees. **Driver comes with dimming compatible 0-10 volts.**

The current supplying the LEDs will be reduced by the driver if the driver experiences internal overheating as a protection to the LEDs and the electrical components. Output is protected from short circuits, voltage overload and current overload. Automatic recovery after correction. Standard built-in driver surge protection of 2.5kV (min).

**Surge Protector:** Surge protector tested in accordance with ANSI/IEEE C62.45 per ANSI/IEEE C62.41.2 Scenario I Category C High Exposure 10kV/10kA waveforms for Line-Ground, Line-Neutral and Neutral-Ground, and in accordance with U.S. DOE (Department of Energy) MSSLC (Municipal Solid-State Street Lighting Consortium) model specification for LED roadway luminaires electrical immunity requirements for High Test Level 10kV / 10kA.

**Fitter:** Made of die cast A360.1 Aluminum alloy 0.100 (2.5mm) minimum thickness, the fitter is complete with a watertight access door giving access to the driver rated IP66, and a terminal block that accepts (#2 max.) wires from the primary circuit. Comes with an easy self-adjusting system with two (2) set screws 3/8 16 UNC for ease of maintenance and installation. Fits on a 4"(102mm) outside diameter by 4"(102mm) long tenon.

**Luminaire Options: (RCD)**, Receptacle with 5 pins enabling dimming, can be used with a twist-lock control device or photoelectric cell or a shorting cap. Use of photocell or shorting cap is required to ensure proper illumination.

Miscellaneous

**Description of Components:**

**Wiring:** The connection of the luminaire is done using a terminal block connector 600V, 85A for use with bare son (#2 max.) wires from the primary circuit, located inside the fitter.

**Hardware:** All exposed screws shall be complete with Ceramic primer-seal basecoat to reduce seizing of the parts and offers a high resistance to corrosion. All seals and sealing devices are made and/or lined with EPDM and/or silicone and/or rubber.

**Finish:** Color to be **natural aluminum paint (NP)** and in accordance with the AAMA 2603 standard. Application of polyester powder coat paint (4 mils/100 microns) with  $\pm 1$  mils/24 microns of tolerance. The Thermosetting resins provides a discoloration resistant finish in accordance with the ASTM D2244 standard, as well as luster retention in keeping with the ASTM D523 standard and humidity proof in accordance with the ASTM D2247 standard.

The surface treatment achieves a minimum of 2000 hours for salt spray resistant finish in accordance with testing performed and per ASTM B117 standard.

**LED products manufacturing standard:** The electronic components sensitive to electrostatic discharge (ESD) such as light emitting diodes (LEDs) are assembled in compliance with IEC61340-5-1 and ANSI/ESD S20.20 standards so as to eliminate ESD events that could decrease the useful life of the product.

**Quality Control:** The manufacturer must provide a written confirmation of its ISO 9001-2008 and ISO 14001-2004 International Quality Standards Certification.

**Vibration Resistance:** The MPTC meets the **ANSI C136.31**, American National Standard for Roadway Luminaire Vibration specifications for Bridge/overpass applications. (Tested for 3G over 100 000 cycles by an independent lab)

**Web site information details:** Click on any specific information details you need:

[Paint finish](#) / [Warranties](#) / [Installation pictures](#) / [ISO 9001-2008 Certification](#) / [ISO 14001-2004 Certification](#) / [cULus Certification](#)



LEDGINE

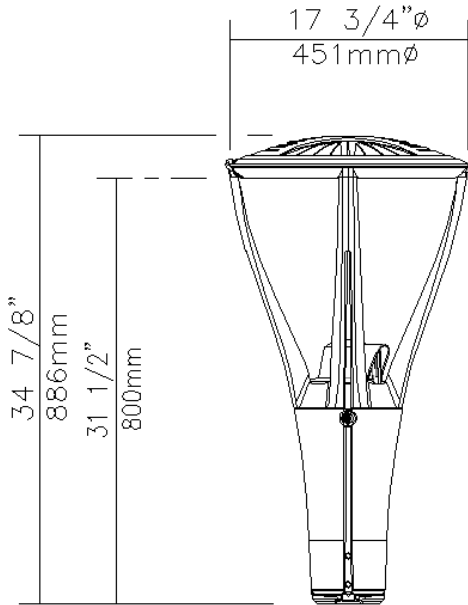

EPA: 1.698 sq ft / weight: 32.2 lb (14.6 kg)

Note: 3D image may not represent color or option selected.  
Logos above include link, click to access.

Qty	1	Luminaire	MPTC-80W48LED4K-T-LE3-UNIV-RCD-NP
-----	---	-----------	-----------------------------------

**Description of Components:**

**Hood:** Made of die cast A360.1 Aluminum alloy 0.100 (2.5mm) minimum thickness, mechanically assembled to the cast aluminum heat sink.

**Guard:** In a round shape with 4 arms and a built-in mechanical ring, this guard is a one piece die cast A360 Aluminum alloy 0.100 (2.5mm) minimum thickness, mechanically assembled to the fitter.

**Access-Mechanism:** A die cast A360.1 Aluminum alloy 0.100 (2.5mm) minimum thickness technical ring with latch and hinge.

**Light Engine: LEDgine** composed of 4 main components: **Heat Sink / LED Module / Optical System / Driver**  
Electrical components are RoHS compliant. Maximum ambient operating temperature up to 40C(104F) degrees.

**Heat Sink:** Made of cast aluminum optimising the LEDs efficiency and life. Product does not use any cooling device with moving parts (only passive cooling device).

**Lens:** Made of soda-lime tempered glass lens, mechanically assembled and sealed onto the ring of the access mechanism.

**LED Module:** LED type Philips Lumileds LUXEON T. Composed of 48 high-performance white LEDs. Color temperature as per ANSI/NEMA bin Neutral White, 4000 Kelvin nominal (3985K +/- 275K or 3710K to 4260K), CRI 70 Min. 75 Typical.

**Optical System:** (LE3), IES type III (asymmetrical). Composed of high-performance optical polymer refractor lenses to achieve desired distribution optimized to get maximum spacing, target lumens and a superior lighting uniformity. System is rated IP66. Performance shall be tested per LM-63, LM-79 and TM-15 (IESNA) certifying its photometric performance. Street

side indicated. Dark Sky compliant with 0% uplight and U0 per IESNA TM-15.

**Driver:** High power factor of 90% minimum. Electronic driver, operating range 50/60 Hz. **Auto-adjusting universal voltage input from 120 to 277 VAC rated for both application line to line or line to neutral, Class I**, THD of 20% max. Maximum ambient operating temperature from -40F(-40C) to 130F(55C) degrees. Assembled on a unitized removable tray with Tyco quick disconnect plug resisting to 221F(105C) degrees. **Driver comes with dimming compatible 0-10 volts.**

The current supplying the LEDs will be reduced by the driver if the driver experiences internal overheating as a protection to the LEDs and the electrical components. Output is protected from short circuits, voltage overload and current overload. Automatic recovery after correction. Standard built-in driver surge protection of 2.5kV (min).

**Surge Protector:** Surge protector tested in accordance with ANSI/IEEE C62.45 per ANSI/IEEE C62.41.2 Scenario I Category C High Exposure 10kV/10kA waveforms for Line-Ground, Line-Neutral and Neutral-Ground, and in accordance with U.S. DOE (Department of Energy) MSSLC (Municipal Solid-State Street Lighting Consortium) model specification for LED roadway luminaires electrical immunity requirements for High Test Level 10kV / 10kA.

**Fitter:** Made of die cast A360.1 Aluminum alloy 0.100 (2.5mm) minimum thickness, the fitter is complete with a watertight access door giving access to the driver rated IP66, and a terminal block that accepts (#2 max.) wires from the primary circuit. Comes with an easy self-adjusting system with two (2) set screws 3/8 16 UNC for ease of maintenance and installation. Fits on a 4"(102mm) outside diameter by 4"(102mm) long tenon.

**Luminaire Options: (RCD)**, Receptacle with 5 pins enabling dimming, can be used with a twist-lock control device or photoelectric cell or a shorting cap. Use of photocell or shorting cap is required to ensure proper illumination.

Miscellaneous

**Description of Components:**

**Wiring:** The connection of the luminaire is done using a terminal block connector 600V, 85A for use with bare son (#2 max.) wires from the primary circuit, located inside the fitter.

**Hardware:** All exposed screws shall be complete with Ceramic primer-seal basecoat to reduce seizing of the parts and offers a high resistance to corrosion. All seals and sealing devices are made and/or lined with EPDM and/or silicone and/or rubber.

**Finish:** Color to be **natural aluminum paint (NP)** and in accordance with the AAMA 2603 standard. Application of polyester powder coat paint (4 mils/100 microns) with  $\pm 1$  mils/24 microns of tolerance. The Thermosetting resins provides a discoloration resistant finish in accordance with the ASTM D2244 standard, as well as luster retention in keeping with the ASTM D523 standard and humidity proof in accordance with the ASTM D2247 standard.

The surface treatment achieves a minimum of 2000 hours for salt spray resistant finish in accordance with testing performed and per ASTM B117 standard.

**LED products manufacturing standard:** The electronic components sensitive to electrostatic discharge (ESD) such as light emitting diodes (LEDs) are assembled in compliance with IEC61340-5-1 and ANSI/ESD S20.20 standards so as to eliminate ESD events that could decrease the useful life of the product.

**Quality Control:** The manufacturer must provide a written confirmation of its ISO 9001-2008 and ISO 14001-2004 International Quality Standards Certification.

**Vibration Resistance:** The MPTC meets the **ANSI C136.31**, American National Standard for Roadway Luminaire Vibration specifications for Bridge/overpass applications. (Tested for 3G over 100 000 cycles by an independent lab)

**Web site information details:** Click on any specific information details you need:

[Paint finish](#) / [Warranties](#) / [Installation pictures](#) / [ISO 9001-2008 Certification](#) / [ISO 14001-2004 Certification](#) / [cULus Certification](#)

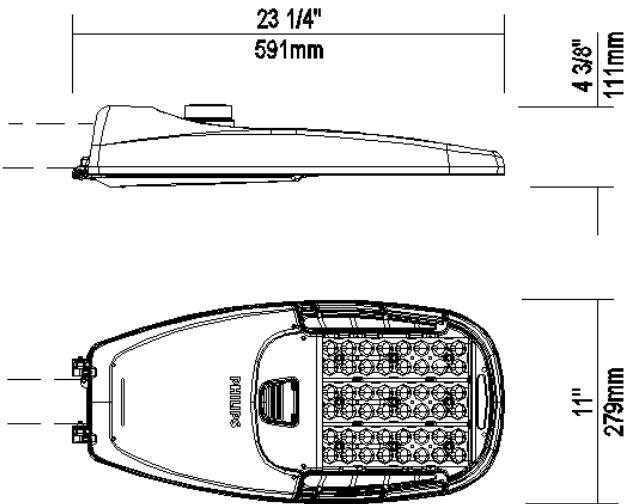

EPA: 0.523 sq ft / weight: 12.3 lb (5.6 kg)  
 Note: 3D image may not represent color or option selected.  
 Logos above include link, click to access.

Qty	1	Luminaire	RFM-72W32LED4K-T-R3M-UNIV-DMG-RCD-GY3
-----	---	-----------	---------------------------------------

**Description of Components:**

**Housing:** Made of a low copper die cast Aluminum alloy (A360), 0.100" (2.5mm) minimum thickness. Fits on a 1.66" (42mm) O.D. (1.25" NPS), 1.9" (48mm) O.D. (1.5" NPS) or 2 3/8" (60mm) O.D. (2" NPS) by 5 1/2" (140mm) minimum long tenon. Comes with a zinc plated clamp fixed by 2 zinc plated hexagonal bolts 3/8 16 UNC for ease of installation. Provides an easy step adjustment of +/- 5° tilt in 2.5° increments. Includes integral bubble level standard (always included). A quick release, tool less entry, single latch, hinged, removable door opens downward to provide access to electronic components and to a terminal block. Door is secured to prevent accidental dropping or disengagement. A clearance of 13" (330mm) at the rear is required in order to remove the door. Complete with a bird guard protecting against birds and similar intruders and an ANSI label to identify wattage and source (both included in box).

**Light Engine:** Composed of 4 main components: **Heat Sink / LED Module / Optical System / Driver**  
 Electrical components are RoHS compliant, IP66 sealed light engine equipped with Philips Lumileds LUXEON T LEDs. LEDs tested by ISO 17025-2005 accredited lab in accordance with IESNA LM-80 guidelines in compliance with EPA ENERGY STAR, extrapolations in accordance with IESNA TM-21. Metal core board ensures greater heat transfer and longer lifespan.

**Heat Sink:** Built in the housing, designed to ensure high efficacy and superior cooling by natural vertical convection air flow pattern always close to LEDs and driver optimising their efficiency and life. Product does not use any cooling device with moving parts (only passive cooling). Wide openings enable natural cleaning and removal of dirt and debris. Entire luminaire is rated for operation in ambient temperature of -40°C / -40°F up to +50°C / +122°F.

**LED Module:** LED type Philips Lumileds LUXEON T. Composed of 32 high-performance white LEDs. Color temperature as per ANSI/NEMA bin Neutral White, 4000 Kelvin nominal (3985K +/- 275K or 3710K to 4260K), CRI 70 Min. 75 Typical.

**Optical System:** (R3M), IES type III medium (asymmetrical). Composed of high-performance UV stabilized optical grade polymer refractor lenses to achieve desired distribution optimized to get maximum spacing, target lumens and a superior lighting uniformity. System is rated IP66. Performance shall be tested per LM-63, LM-79 and TM-15 (IESNA) certifying its photometric performance. Dark Sky compliant with 0% uplight and U0 per IESNA TM-15.

**Driver:** High power factor of 90% minimum. Electronic driver, operating range 50/60 Hz. Auto-adjusting universal voltage input from 120 to 277 VAC rated for both application line to line or line to neutral, Class I, THD of 20% max. **Driver comes with dimming compatible 0-10 volts.**

The current supplying the LEDs will be reduced by the driver if the driver experiences internal overheating as a protection to the LEDs and the electrical components. Output is protected from short circuits, voltage overload and current overload. Automatic recovery after correction. Standard built-in driver surge protection of 2.5kV (min).

**Driver Options: (DMG) Integrated Feature,** Dimming compatible 0-10 volts. For applicable warranty, certification and operation guide see Philips Lumec dimmable luminaire specification document for unapproved device installed by other. To get document, click on this link: [Specification document](http://www.lumec.com/Lumec3DV2/PdfWebLink/Philips%20Lumec%20dimmable%20luminaire%20specification%20document%20for%20unapproved%20device%20installed%20by%20other.pdf) or go on web site on this address: <http://www.lumec.com/Lumec3DV2/PdfWebLink/Philips Lumec dimmable luminaire specification document for unapproved device installed by other.pdf>

**Surge Protector: Integrated Feature,** Surge protector tested in accordance with ANSI/IEEE C62.45 per ANSI/IEEE C62.41.2 Scenario I Category C High Exposure 10kV/10kA waveforms for Line-Ground, Line-Neutral and Neutral-Ground, and in accordance with U.S. DOE (Department of Energy) MSSLC (Municipal Solid-State Street Lighting Consortium) model specification for LED roadway luminaires electrical immunity requirements for High Test Level 10kV / 10kA.

**Luminaire Options: (RCD) Integrated Feature,** Receptacle with 5 pins enabling dimming, can be used with a twist-lock control device or photoelectric cell or a shorting cap. Use of photocell or shorting cap is required to ensure proper illumination.

**Luminaire Useful Life:** Refer to IES files for energy consumption and delivered lumens for each option. Based on ISTMT in-situ thermal testing in accordance with UL1598 and UL8750, Philips System Reliability Tool. Philips Advance data and Philips Lumileds LM-80/TM-21 data, expected to reach 100,000 + hours with >L70 lumen maintenance @ 25°C. Luminaire Useful Life accounts for LED lumen maintenance AND all of these additional factors including: LED life, driver life, PCB substrate, solder joints, on/off cycles, burning hours and corrosion.



Miscellaneous

**Description of Components:**

**Wiring:** The connection of the luminaire is done using a terminal block connector 600V, 85A for use with #2-14 AWG. wires from the primary circuit, located inside the housing. Due to the inrush current that occurs with electronic drivers, recommend using a 10Amp time delay fuse to avoid unwanted fuse blowing (false tripping) that can occur with normal or fast acting fuses.

**Hardware:** All exposed screws shall be complete with Ceramic primer-seal basecoat to reduce seizing of the parts and offers a high resistance to corrosion. All seals and sealing devices are made and/or lined with EPDM and/or silicone and/or rubber.

**Finish:** Color to be **medium grey (GY3)** and in accordance with the AAMA 2603 standard. Application of polyester powder coat paint (4 mils/100 microns) with  $\pm 1$  mils/24 microns of tolerance. The Thermosetting resins provides a discoloration resistant finish in accordance with the ASTM D2244 standard, as well as luster retention in keeping with the ASTM D523 standard and humidity proof in accordance with the ASTM D2247 standard.

The surface treatment achieves a minimum of 3000 hours for salt spray resistant finish in accordance with testing performed and per ASTM B117 standard.

**LED products manufacturing standard:** The electronic components sensitive to electrostatic discharge (ESD) such as light emitting diodes (LEDs) are assembled in compliance with IEC61340-5-1 and ANSI/ESD S20.20 standards so as to eliminate ESD events that could decrease the useful life of the product.

**Vibration Resistance:** The RFM meets the **ANSI C136.31**, American National Standard for Roadway Luminaire Vibration specifications for Bridge/overpass applications (Tested for 3G over 100 000 cycles by an independent lab).

The RFM meets the **California Test 611, Testing durability of mast arm mounted luminaires**, specifications (a 2 000 000 cycle test by an independent lab).

**Warranty:** Luminaire comes with a warranty of 10 years on product and finish. See <http://www.usa.lighting.philips.com/support/support/warranty> for details.

**Certifications and Compliance:** cULus Listed for Canada and USA. Luminaire meets DOE and MSSLC Model Specification for LED Roadway Luminaires. Medium RoadFocus luminaires are DesignLights Consortium qualified. Luminaire complies with or exceeds the following ANSI C136 standards: .2, .3, .10, .14, .15, .22, .25, .31, .37, .41.

**Web site information details:** Click on any specific information details you need: / [cULus Certification](#) / [Warranty](#)

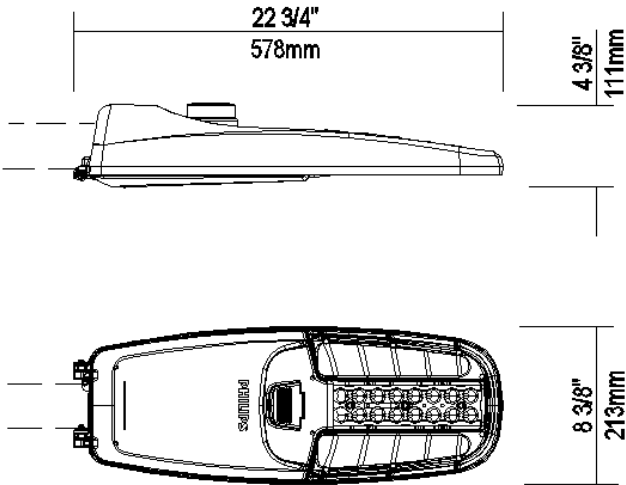

EPA: 0.52 sq ft / weight: 9.4 lb (4.3 kg)  
 Note: 3D image may not represent color or option selected.  
 Logos above include link, click to access.

Qty	1	Luminaire	RFS-35W16LED4K-T-R3M-UNIV-DMG-RCD-GY3
-----	---	-----------	---------------------------------------

**Description of Components:**

**Housing:** Made of a low copper die cast Aluminum alloy (A360), 0.100" (2.5mm) minimum thickness. Fits on a 1.66" (42mm) O.D. (1.25" NPS), 1.9" (48mm) O.D. (1.5" NPS) or 2 3/8" (60mm) O.D. (2" NPS) by 5 1/2" (140mm) minimum long tenon. Comes with a zinc plated clamp fixed by 2 zinc plated hexagonal bolts 3/8 16 UNC for ease of installation. Provides an easy step adjustment of +/- 5° tilt in 2.5° increments. Includes integral bubble level standard (always included). A quick release, tool less entry, single latch, hinged, removable door opens downward to provide access to electronic components and to a terminal block. Door is secured to prevent accidental dropping or disengagement. A clearance of 13" (330mm) at the rear is required in order to remove the door. Complete with a bird guard protecting against birds and similar intruders and an ANSI label to identify wattage and source (both included in box).

**Light Engine:** Composed of 4 main components: **Heat Sink / LED Module / Optical System / Driver**  
 Electrical components are RoHS compliant, IP66 sealed light engine equipped with Philips Lumileds LUXEON T LEDs. LEDs tested by ISO 17025-2005 accredited lab in accordance with IESNA LM-80 guidelines in compliance with EPA ENERGY STAR, extrapolations in accordance with IESNA TM-21. Metal core board ensures greater heat transfer and longer lifespan.

**Heat Sink:** Built in the housing, designed to ensure high efficacy and superior cooling by natural vertical convection air flow pattern always close to LEDs and driver optimising their efficiency and life. Product does not use any cooling device with moving parts (only passive cooling). Wide openings enable natural cleaning and removal of dirt and debris. Entire luminaire is rated for operation in ambient temperature of -40°C / -40°F up to +50°C / +122°F.

**LED Module:** LED type Philips Lumileds LUXEON T. Composed of 16 high-performance white LEDs. Color temperature as per ANSI/NEMA bin Neutral White, 4000 Kelvin nominal (3985K +/- 275K or 3710K to 4260K), CRI 70 Min. 75 Typical.



**Optical System:** (R3M), IES type III medium (asymmetrical). Composed of high-performance UV stabilized optical grade polymer refractor lenses to achieve desired distribution optimized to get maximum spacing, target lumens and a superior lighting uniformity. System is rated IP66. Performance shall be tested per LM-63, LM-79 and TM-15 (IESNA) certifying its photometric performance. Dark Sky compliant with 0% uplight and U0 per IESNA TM-15.

**Driver:** High power factor of 90% min. Electronic driver, operating range 50/60 Hz. Auto-adjusting universal voltage input from 120 to 277 VAC rated for both application line to line or line to neutral, Class II, THD of 20% max. **Driver comes with dimming compatible 0-10 volts.**

The current supplying the LEDs will be reduced by the driver if the driver experiences internal overheating as a protection to the LEDs and the electrical components. Output is protected from short circuits, voltage overload and current overload. Automatic recovery after correction. Standard built-in driver surge protection of 2.5kV (min).

**Driver Options: (DMG) Integrated Feature,** Dimming compatible 0-10 volts. For applicable warranty, certification and operation guide see Philips Lumec dimmable luminaire specification document for unapproved device installed by other. To get document, click on this link: [Specification document](http://www.lumec.com/Lumec3DV2/PdfWebLink/Philips%20Lumec%20dimmable%20luminaire%20specification%20document%20for%20unapproved%20device%20installed%20by%20other.pdf) or go on web site on this address: <http://www.lumec.com/Lumec3DV2/PdfWebLink/Philips Lumec dimmable luminaire specification document for unapproved device installed by other.pdf>

**Surge Protector: Integrated Feature,** Surge protector tested in accordance with ANSI/IEEE C62.45 per ANSI/IEEE C62.41.2 Scenario I Category C High Exposure 10kV/10kA waveforms for Line-Ground, Line-Neutral and Neutral-Ground, and in accordance with U.S. DOE (Department of Energy) MSSLC (Municipal Solid-State Street Lighting Consortium) model specification for LED roadway luminaires electrical immunity requirements for High Test Level 10kV / 10kA.

**Luminaire Options: (RCD) Integrated Feature,** Receptacle with 5 pins enabling dimming, can be used with a twist-lock control device or photoelectric cell or a shorting cap. Use of photocell or shorting cap is required to ensure proper illumination.

**Luminaire Useful Life:** Refer to IES files for energy consumption and delivered lumens for each option. Based on ISTMT in-situ thermal testing in accordance with UL1598 and UL8750, Philips System Reliability Tool. Philips Advance data and Philips Lumileds LM-80/TM-21 data, expected to reach 100,000 + hours with >L70 lumen maintenance @ 25°C. Luminaire Useful Life accounts for LED lumen maintenance AND all of these additional factors including: LED life, driver life, PCB substrate, solder joints, on/off cycles, burning hours and corrosion.

Miscellaneous

**Description of Components:**

**Wiring:** The connection of the luminaire is done using a terminal block connector 600V, 85A for use with #2-14 AWG. wires from the primary circuit, located inside the housing. Due to the inrush current that occurs with electronic drivers, recommend using a 10Amp time delay fuse to avoid unwanted fuse blowing (false tripping) that can occur with normal or fast acting fuses.

**Hardware:** All exposed screws shall be complete with Ceramic primer-seal basecoat to reduce seizing of the parts and offers a high resistance to corrosion. All seals and sealing devices are made and/or lined with EPDM and/or silicone and/or rubber.

**Finish:** Color to be **medium grey (GY3)** and in accordance with the AAMA 2603 standard. Application of polyester powder coat paint (4 mils/100 microns) with  $\pm 1$  mils/24 microns of tolerance. The Thermosetting resins provides a discoloration resistant finish in accordance with the ASTM D2244 standard, as well as luster retention in keeping with the ASTM D523 standard and humidity proof in accordance with the ASTM D2247 standard.

The surface treatment achieves a minimum of 3000 hours for salt spray resistant finish in accordance with testing performed and per ASTM B117 standard.

**LED products manufacturing standard:** The electronic components sensitive to electrostatic discharge (ESD) such as light emitting diodes (LEDs) are assembled in compliance with IEC61340-5-1 and ANSI/ESD S20.20 standards so as to eliminate ESD events that could decrease the useful life of the product.

**Vibration Resistance:** The RFS meets the **ANSI C136.31**, American National Standard for Roadway Luminaire Vibration specifications for Bridge/overpass applications (Tested for 3G over 100 000 cycles by an independent lab).

The RFS meets the **California Test 611, Testing durability of mast arm mounted luminaires**, specifications (a 2 000 000 cycle test by an independent lab).

**Warranty:** Luminaire comes with a warranty of 10 years on product and finish. See <http://www.usa.lighting.philips.com/support/support/warranty> for details.

**Certifications and Compliance:** cULus Listed for Canada and USA. Luminaire meets DOE and MSSLC Model Specification for LED Roadway Luminaires. Small RoadFocus luminaires are DesignLights Consortium qualified. Luminaire complies with or exceeds the following ANSI C136 standards: .2, .3, .10, .14, .15, .22, .25, .31, .37, .41.

**Web site information details:** Click on any specific information details you need: / [cULus Certification](#) / [Warranty](#)

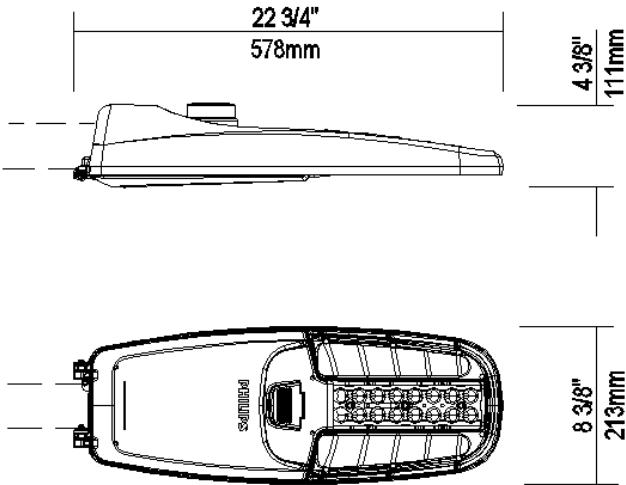

EPA: 0.52 sq ft / weight: 9.4 lb (4.3 kg)  
 Note: 3D image may not represent color or option selected.  
 Logos above include link, click to access.

Qty	1	Luminaire	RFS-54W16LED4K-T-R3M-UNIV-DMG-RCD-GY3
-----	---	-----------	---------------------------------------

**Description of Components:**

**Housing:** Made of a low copper die cast Aluminum alloy (A360), 0.100" (2.5mm) minimum thickness. Fits on a 1.66" (42mm) O.D. (1.25" NPS), 1.9" (48mm) O.D. (1.5" NPS) or 2 3/8" (60mm) O.D. (2" NPS) by 5 1/2" (140mm) minimum long tenon. Comes with a zinc plated clamp fixed by 2 zinc plated hexagonal bolts 3/8 16 UNC for ease of installation. Provides an easy step adjustment of +/- 5° tilt in 2.5° increments. Includes integral bubble level standard (always included). A quick release, tool less entry, single latch, hinged, removable door opens downward to provide access to electronic components and to a terminal block. Door is secured to prevent accidental dropping or disengagement. A clearance of 13" (330mm) at the rear is required in order to remove the door. Complete with a bird guard protecting against birds and similar intruders and an ANSI label to identify wattage and source (both included in box).

**Light Engine:** Composed of 4 main components: **Heat Sink / LED Module / Optical System / Driver**  
 Electrical components are RoHS compliant, IP66 sealed light engine equipped with Philips Lumileds LUXEON T LEDs. LEDs tested by ISO 17025-2005 accredited lab in accordance with IESNA LM-80 guidelines in compliance with EPA ENERGY STAR, extrapolations in accordance with IESNA TM-21. Metal core board ensures greater heat transfer and longer lifespan.

**Heat Sink:** Built in the housing, designed to ensure high efficacy and superior cooling by natural vertical convection air flow pattern always close to LEDs and driver optimising their efficiency and life. Product does not use any cooling device with moving parts (only passive cooling). Wide openings enable natural cleaning and removal of dirt and debris. Entire luminaire is rated for operation in ambient temperature of -40°C / -40°F up to +50°C / +122°F.

**LED Module:** LED type Philips Lumileds LUXEON T. Composed of 16 high-performance white LEDs. Color temperature as per ANSI/NEMA bin Neutral White, 4000 Kelvin nominal (3985K +/- 275K or 3710K to 4260K), CRI 70 Min. 75 Typical.

**Optical System:** (R3M), IES type III medium (asymmetrical). Composed of high-performance UV stabilized optical grade polymer refractor lenses to achieve desired distribution optimized to get maximum spacing, target lumens and a superior lighting uniformity. System is rated IP66. Performance shall be tested per LM-63, LM-79 and TM-15 (IESNA) certifying its photometric performance. Dark Sky compliant with 0% uplight and U0 per IESNA TM-15.

**Driver:** High power factor of 90% min. Electronic driver, operating range 50/60 Hz. Auto-adjusting universal voltage input from 120 to 277 VAC rated for both application line to line or line to neutral, Class II, THD of 20% max. **Driver comes with dimming compatible 0-10 volts.**

The current supplying the LEDs will be reduced by the driver if the driver experiences internal overheating as a protection to the LEDs and the electrical components. Output is protected from short circuits, voltage overload and current overload. Automatic recovery after correction. Standard built-in driver surge protection of 2.5kV (min).

**Driver Options: (DMG) Integrated Feature,** Dimming compatible 0-10 volts. For applicable warranty, certification and operation guide see Philips Lumec dimmable luminaire specification document for unapproved device installed by other. To get document, click on this link: [Specification document](http://www.lumec.com/Lumec3DV2/PdfWebLink/Philips%20Lumec%20dimmable%20luminaire%20specification%20document%20for%20unapproved%20device%20installed%20by%20other.pdf) or go on web site on this address: <http://www.lumec.com/Lumec3DV2/PdfWebLink/Philips Lumec dimmable luminaire specification document for unapproved device installed by other.pdf>

**Surge Protector: Integrated Feature,** Surge protector tested in accordance with ANSI/IEEE C62.45 per ANSI/IEEE C62.41.2 Scenario I Category C High Exposure 10kV/10kA waveforms for Line-Ground, Line-Neutral and Neutral-Ground, and in accordance with U.S. DOE (Department of Energy) MSSLC (Municipal Solid-State Street Lighting Consortium) model specification for LED roadway luminaires electrical immunity requirements for High Test Level 10kV / 10kA.

**Luminaire Options: (RCD) Integrated Feature,** Receptacle with 5 pins enabling dimming, can be used with a twist-lock control device or photoelectric cell or a shorting cap. Use of photocell or shorting cap is required to ensure proper illumination.

**Luminaire Useful Life:** Refer to IES files for energy consumption and delivered lumens for each option. Based on ISTMT in-situ thermal testing in accordance with UL1598 and UL8750, Philips System Reliability Tool. Philips Advance data and Philips Lumileds LM-80/TM-21 data, expected to reach 100,000 + hours with >L70 lumen maintenance @ 25°C. Luminaire Useful Life accounts for LED lumen maintenance AND all of these additional factors including: LED life, driver life, PCB substrate, solder joints, on/off cycles, burning hours and corrosion.

Miscellaneous

**Description of Components:**

**Wiring:** The connection of the luminaire is done using a terminal block connector 600V, 85A for use with #2-14 AWG. wires from the primary circuit, located inside the housing. Due to the inrush current that occurs with electronic drivers, recommend using a 10Amp time delay fuse to avoid unwanted fuse blowing (false tripping) that can occur with normal or fast acting fuses.

**Hardware:** All exposed screws shall be complete with Ceramic primer-seal basecoat to reduce seizing of the parts and offers a high resistance to corrosion. All seals and sealing devices are made and/or lined with EPDM and/or silicone and/or rubber.

**Finish:** Color to be **medium grey (GY3)** and in accordance with the AAMA 2603 standard. Application of polyester powder coat paint (4 mils/100 microns) with  $\pm 1$  mils/24 microns of tolerance. The Thermosetting resins provides a discoloration resistant finish in accordance with the ASTM D2244 standard, as well as luster retention in keeping with the ASTM D523 standard and humidity proof in accordance with the ASTM D2247 standard.

The surface treatment achieves a minimum of 3000 hours for salt spray resistant finish in accordance with testing performed and per ASTM B117 standard.

**LED products manufacturing standard:** The electronic components sensitive to electrostatic discharge (ESD) such as light emitting diodes (LEDs) are assembled in compliance with IEC61340-5-1 and ANSI/ESD S20.20 standards so as to eliminate ESD events that could decrease the useful life of the product.

**Vibration Resistance:** The RFS meets the **ANSI C136.31**, American National Standard for Roadway Luminaire Vibration specifications for Bridge/overpass applications (Tested for 3G over 100 000 cycles by an independent lab).

The RFS meets the **California Test 611, Testing durability of mast arm mounted luminaires**, specifications (a 2 000 000 cycle test by an independent lab).

**Warranty:** Luminaire comes with a warranty of 10 years on product and finish. See <http://www.usa.lighting.philips.com/support/support/warranty> for details.

**Certifications and Compliance:** cULus Listed for Canada and USA. Luminaire meets DOE and MSSLC Model Specification for LED Roadway Luminaires. Small RoadFocus luminaires are DesignLights Consortium qualified. Luminaire complies with or exceeds the following ANSI C136 standards: .2, .3, .10, .14, .15, .22, .25, .31, .37, .41.

**Web site information details:** Click on any specific information details you need: / [cULus Certification](#) / [Warranty](#)